

SEGUIN Multivision Hydro80 Hydronic Heating



Your gateway to
**SUSTAINABLE
LIVING**

Hand crafted with raw materials to produce world class elegance and outstanding heating performance, the Seguin Multivision Hydro80 has been engineered to encapsulate your entire home heating solution. This sustainable heating solution delivers superior heat output, delivering heating via your in floor heating systems or radiator panels. The Seguin Multivision Hydro80 provides an efficient solution to your heating needs. Through versatility incorporated into simplicity this design is the ideal solution to heat your home comfortably.



Multivision Hydro80 Single Sided



Multivision Hydro80 VL



Multivision Hydro80 3V

SCULPT™
FIREPLACE
COLLECTION

SEGUIN Multivision Hydro80 Specifications

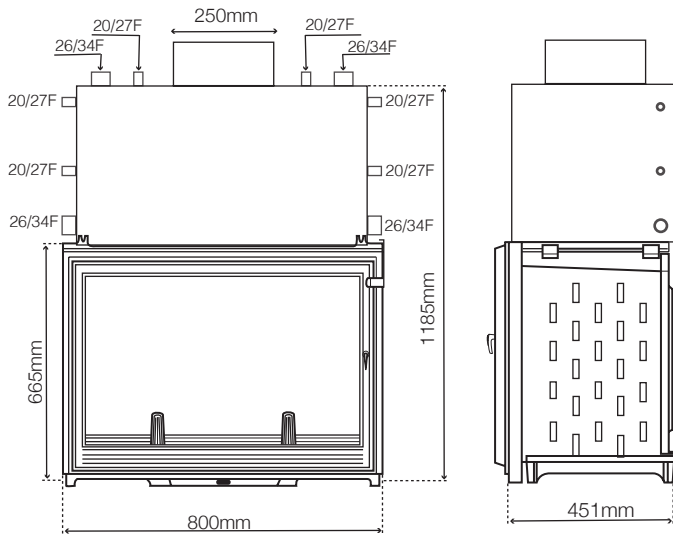

KW Output	Dry model = 25.9kw Wet model= 14.3kw
Facade	Clean frame-less design (no trim)
Glass door	Secure swing door
Minimum flue height	4.6m
Flue sizes	250mm (active), 300mm, 350mm
Includes hot air kit	A duct and register
Outside air kit	Recommended for well insulated homes
Warranty	10 year firebox warranty*
Weight	345kg
Hearth dimensions	Minimum 500mm in front of any part of fireplace, 250mm on either side & 75mm thick*

Why a Hydro80?

The Seguin Multivision Hydro80 provides an eco-friendly solution to your heating needs; with the versatility to be adapted to your in floor heating system or radiant convection panels providing ambient soft heating throughout your home.



Handmade in France



Equipped with Safety Damper



In Floor Heating



Radiator Panel Heating



Includes Fire Grate & Ash Pan

The advantages of hydronic heating

1. Hydronic heating does not dry out the air.
2. No unpleasant draughts, nor does it create humidity, hot spots or noise.
3. Thermal mass is stored and released slowly through its firebox construction.
4. 14kW of heating which can be coupled with a heating solution/ or hydronic heating system
5. Large fire box makes reloading and maintaining your hydronic heating system easier.

* See warranty section in the installation manual for further details.

All images & diagrams in this brochure are for illustration purposes only and are not drawn to scale. E&OE. All wood fireplaces must be installed as per AUS & NZ standards AS/NZS 2918:2018.
© Copyright 2021 Sculpt Fireplaces Collection