

# FAS120 Series

## INSTALLATION & USER GUIDE

---

- FAS120 SS
- FAS120 DS
- FAS120 VLD
- FAS120 VLG
- FAS120 3V

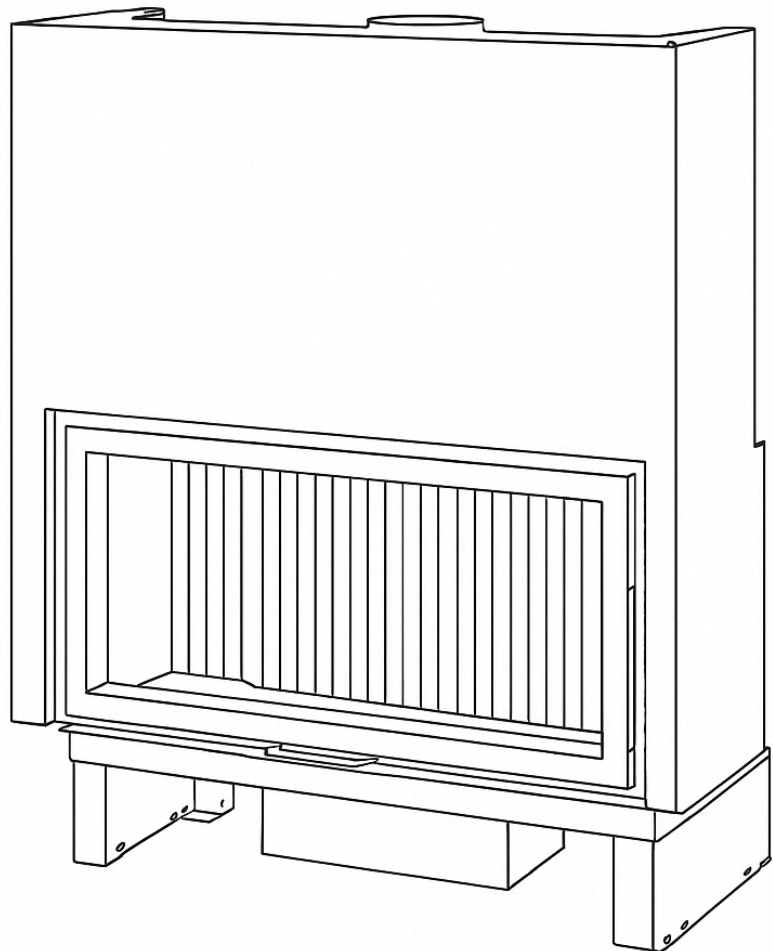

### NOTICE TO INSTALLER:

These instructions must be left with the owner, who should keep them for future use.

# CONGRATULATIONS

Thank you for choosing Sculpt Fireplaces as your heater of choice. Your fireplace is the result of careful design, artisan engineering and safety tests.

If properly installed, used and maintained, you can be sure that you will have an outstanding heating feature in your home for years to come.

We advise you to read through this guide in order to become acquainted with the installation methods specific to your fireplace. It is recommended that this fireplace be installed by a qualified and licensed trades professional. You will find in this guide the answers to most of your questions, should you require further assistance we recommend you contact your retailer.

Before igniting your fireplace for the first time, please carefully read this manual.

Follow @sculptfireplacecollection on Instagram, SculptFireplaceCollection on Facebook and be sure to post your latest masterpiece installed with the hashtag #sculptfires.

We hope we've helped make you the envy of your friends this winter and for years to come.

From all of us,

**Sculpt Fireplace Collection**

# Contents

## 1. Product Overview & Specifications

1.1 Dimensions – FAS120 SS .....	4
1.1 Dimensions – FAS120 DS .....	5
1.1 Dimensions – FAS120 VLD / VLG .....	6
1.1 Dimensions – FAS120 3V .....	7
1.2 Hearth & Clearance – SS / VLD / VLG / 3V .....	8
1.2 Hearth & Clearance – DS .....	9

## 2. Preliminary Information

2.1 Safety Notices & Installation Requirements .....	10
2.2 Important Information .....	11
2.3 Combustion Air Requirements .....	12
2.4 Location & Heat Transfer Requirements .....	13
2.5 Exposure, Materials & Access Requirements .....	14
2.6 Leg Assembly .....	15
2.7 Draft Adjustment Control .....	16
2.8 Hot Air Transfer Kit .....	17
2.9 Outdoor Air .....	18
2.10 Ash Grate .....	19
2.11 Baffle Plates & Flue Requirements .....	20

## 3. Installation Guide

3.1 Standard Installation – Single Sided .....	22-24
3.2 Standard Installation – Double Sided .....	25-26
3.3 Standard Installation – VLD / VLG Models .....	27-28
3.4 Standard Installation – 3V Models .....	29-30
3.5 Installation Guide .....	31-36
3.6 Commissioning Checklist .....	37-38

## 4. User Guide

4.1 User Guide – Troubleshooting .....	40
4.2 User Guide – Operation .....	41-42
4.3 User Guide – Maintenance .....	43-45
4.4 Warranty .....	46-47
4.5 Disclaimer.....	48

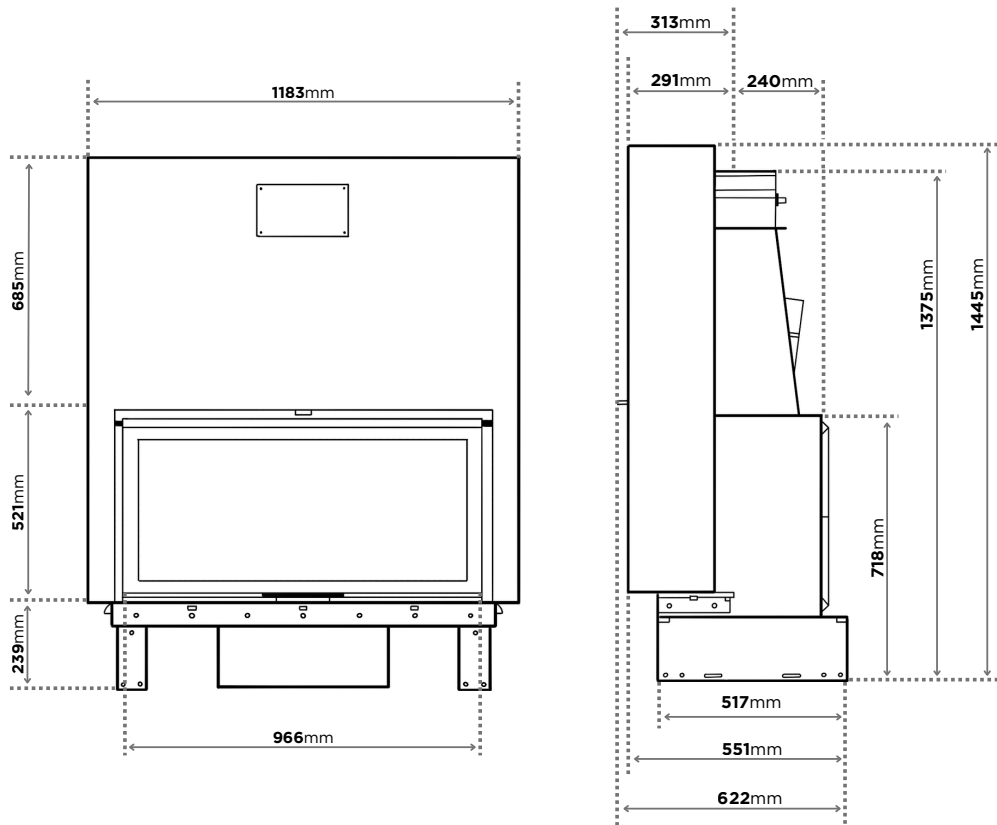

<b>MATERIAL</b>	Steel firebox construction, grooved cast iron internal back panels, and black silk-screen printed ceramic glass.
<b>KW OUTPUT / CAPACITY*</b>	22.5kW
<b>FACADE</b>	Clean frame-less design (trim options available)
<b>GLASS DOOR</b>	Lift and swing door
<b>GLASS VIEWING AREA</b>	966mm W x 474mm H
<b>MINIMUM FLUE HEIGHT</b>	5.4
<b>FLUE SIZES</b>	230 (inner), 280, 330 mm (outer)
<b>OUTSIDE AIR KIT</b>	Optional extra - recommended for well insulated homes Required for 6 star or above rated homes
<b>HOT AIR TRANSFER KIT</b>	Optional extra - transfer heat to other rooms
<b>WARRANTY</b>	10 years on firebox (heating element)
<b>WEIGHT</b>	290kg
<b>LEGS</b>	180mm

\*Heating capacity of the following appliances are a guide only and refers to areas with 2.4m ceilings and 6 or more star rated buildings. Heating output may vary depending on factors such as building characteristics, quality of insulation, type of firewood used and climate zone.

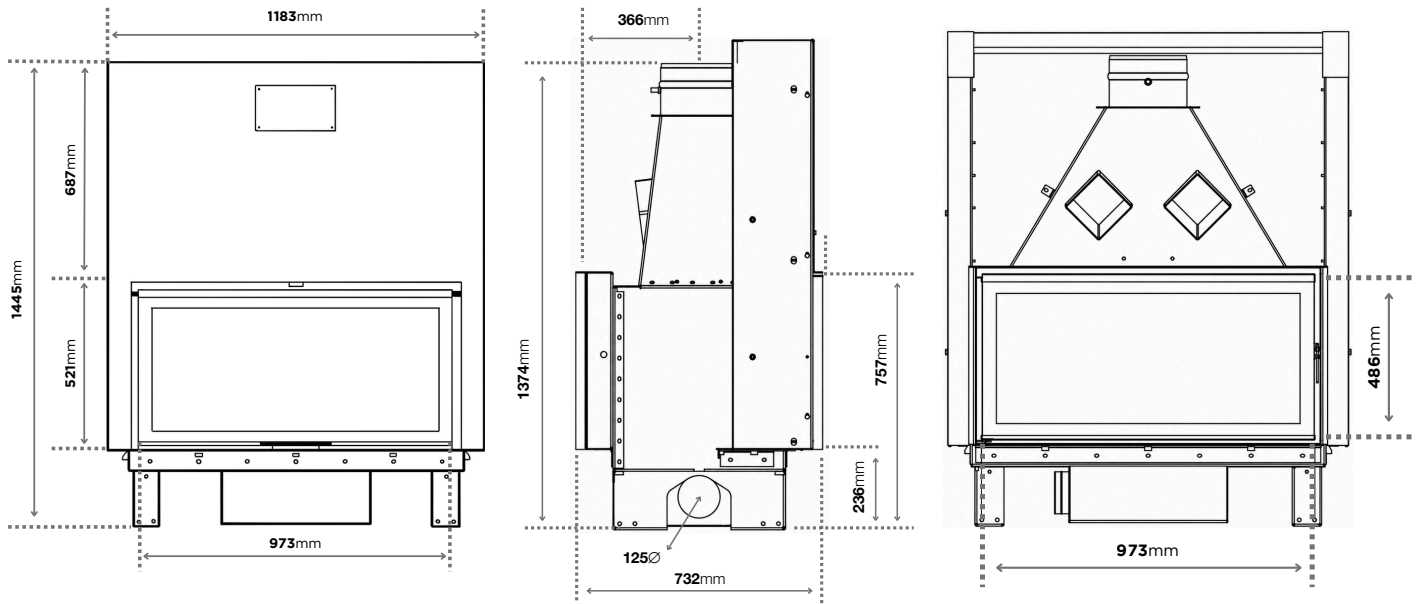

<b>MATERIAL</b>	Steel firebox construction, grooved cast iron internal back panels, and black silk-screen printed ceramic glass.
<b>KW OUTPUT / CAPACITY*</b>	22.5kW
<b>FACADE</b>	Clean frame-less design (trim options available)
<b>GLASS DOOR</b>	Lift and swing door
<b>GLASS VIEWING AREA</b>	966mm W x 474mm H
<b>MINIMUM FLUE HEIGHT</b>	5.4
<b>FLUE SIZES</b>	230 (inner), 280, 330 mm (outer)
<b>OUTSIDE AIR KIT</b>	Optional extra - recommended for well insulated homes Required for 6 star or above rated homes
<b>HOT AIR TRANSFER KIT</b>	Optional extra - transfer heat to other rooms
<b>WARRANTY</b>	10 years on firebox (heating element)
<b>WEIGHT</b>	290kg
<b>LEGS</b>	180mm

\*Heating capacity of the following appliances are a guide only and refers to areas with 2.4m ceilings and 6 or more star rated buildings. Heating output may vary depending on factors such as building characteristics, quality of insulation, type of firewood used and climate zone.

# 1.1 Dimensions

# FAS120 VLD / VLG

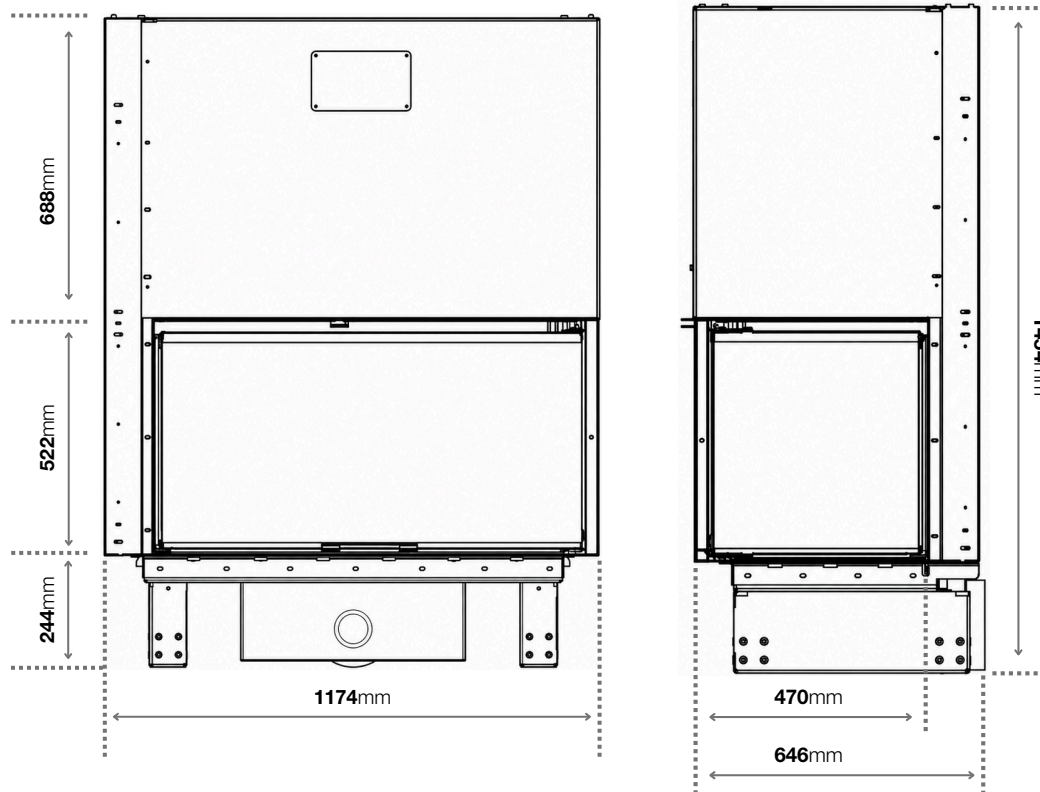

<b>MATERIAL</b>	Steel firebox construction, grooved cast iron internal back panels, and black silk-screen printed ceramic glass.
<b>KW OUTPUT / CAPACITY*</b>	22.5kW
<b>FACADE</b>	Clean frame-less design (trim options available)
<b>GLASS DOOR</b>	Lift and swing door
<b>GLASS VIEWING AREA</b>	Front: 973mm W x 474mm H / Side: 441mm W x 474mm H
<b>MINIMUM FLUE HEIGHT</b>	5.4
<b>FLUE SIZES</b>	230 (inner), 280, 330 mm (outer)
<b>OUTSIDE AIR KIT</b>	Optional extra - recommended for well insulated homes Required for 6 star or above rated homes
<b>HOT AIR TRANSFER KIT</b>	Optional extra - transfer heat to other rooms
<b>WARRANTY</b>	10 years on firebox (heating element)
<b>WEIGHT</b>	290kg
<b>LEGS</b>	180mm

\*Heating capacity of the following appliances are a guide only and refers to areas with 2.4m ceilings and 6 or more star rated buildings. Heating output may vary depending on factors such as building characteristics, quality of insulation, type of firewood used and climate zone.

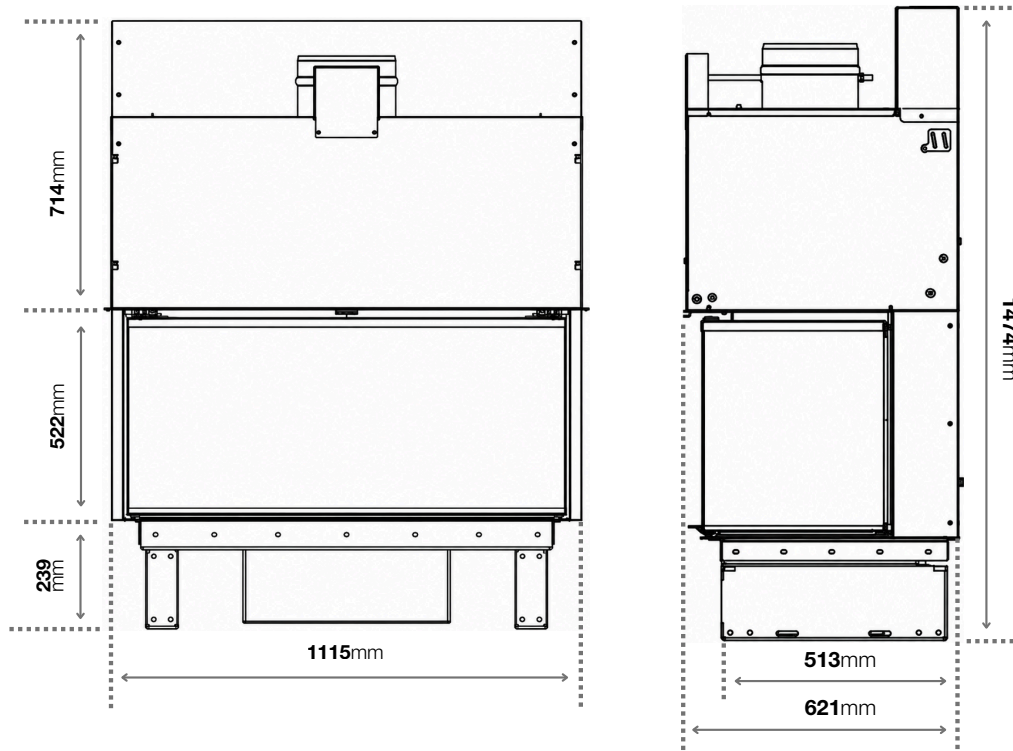

<b>MATERIAL</b>	Steel firebox construction, grooved cast iron internal back panels, and black silk-screen printed ceramic glass.
<b>KW OUTPUT / CAPACITY*</b>	22.5kW
<b>FACADE</b>	Clean frame-less design (trim options available)
<b>GLASS DOOR</b>	Lift and swing door
<b>GLASS VIEWING AREA</b>	Front: 1016mm W x 474mm H / Side: 403mm W x 474mm H
<b>MINIMUM FLUE HEIGHT</b>	5.4
<b>FLUE SIZES</b>	230 (inner), 280, 330 mm (outer)
<b>OUTSIDE AIR KIT</b>	Optional extra - recommended for well insulated homes Required for 6 star or above rated homes
<b>HOT AIR TRANSFER KIT</b>	Optional extra - transfer heat to other rooms
<b>WARRANTY</b>	10 years on firebox (heating element)
<b>WEIGHT</b>	290kg
<b>LEGS</b>	180mm

\*Heating capacity of the following appliances are a guide only and refers to areas with 2.4m ceilings and 6 or more star rated buildings. Heating output may vary depending on factors such as building characteristics, quality of insulation, type of firewood used and climate zone.

TOP VIEW

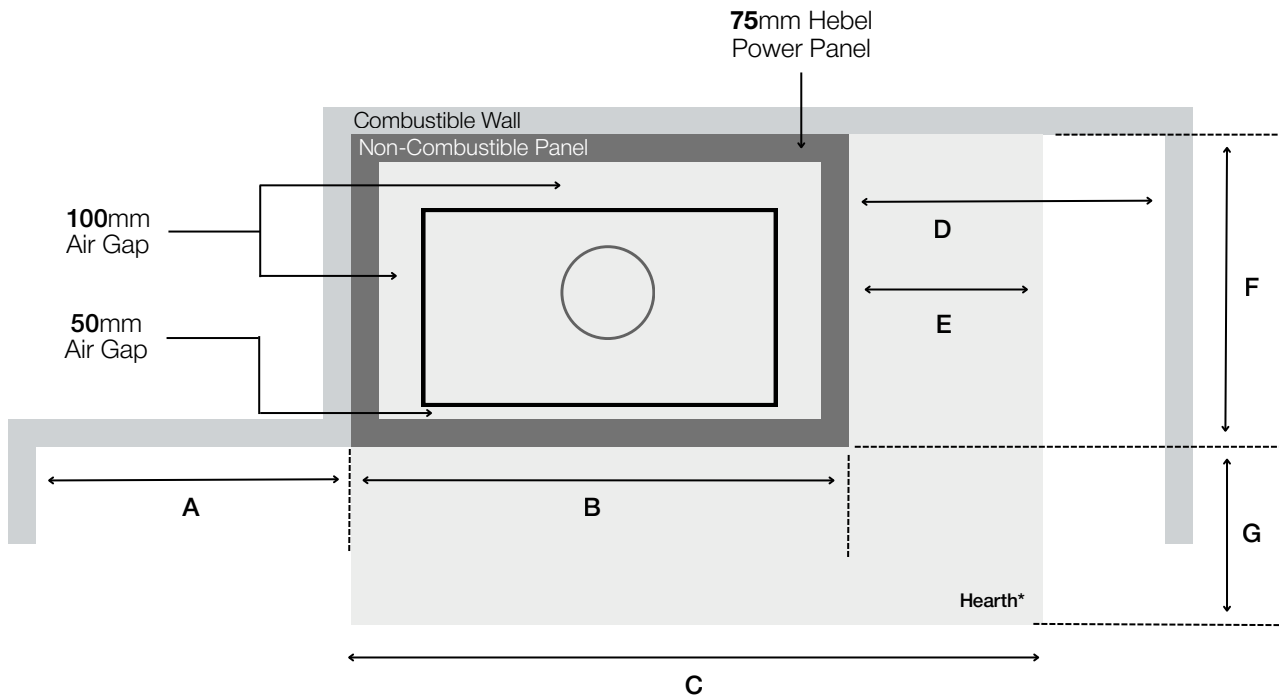

MODEL	A	B	C	D	E	F	G
FAS120 SS	600	1533	1983	600	450	847	450
FAS120 VLD/G	600	1524	1974	600	450	871	450
FAS120 3V	600	1465	1915	600	450	846	450

**NOTE:** Measurements in mm. The above hearth dimensions apply to units installed with a leg height of 300mm or greater.

**CLAUSE:** A mantel shelf and mantel upright clearances were not tested and should be installed as per clause 3.4.1.3(b) of AS/NZS 2918:2018

**\*HEARTH:** The hearth must be a minimum of thickness of **75mm**

## TOP VIEW

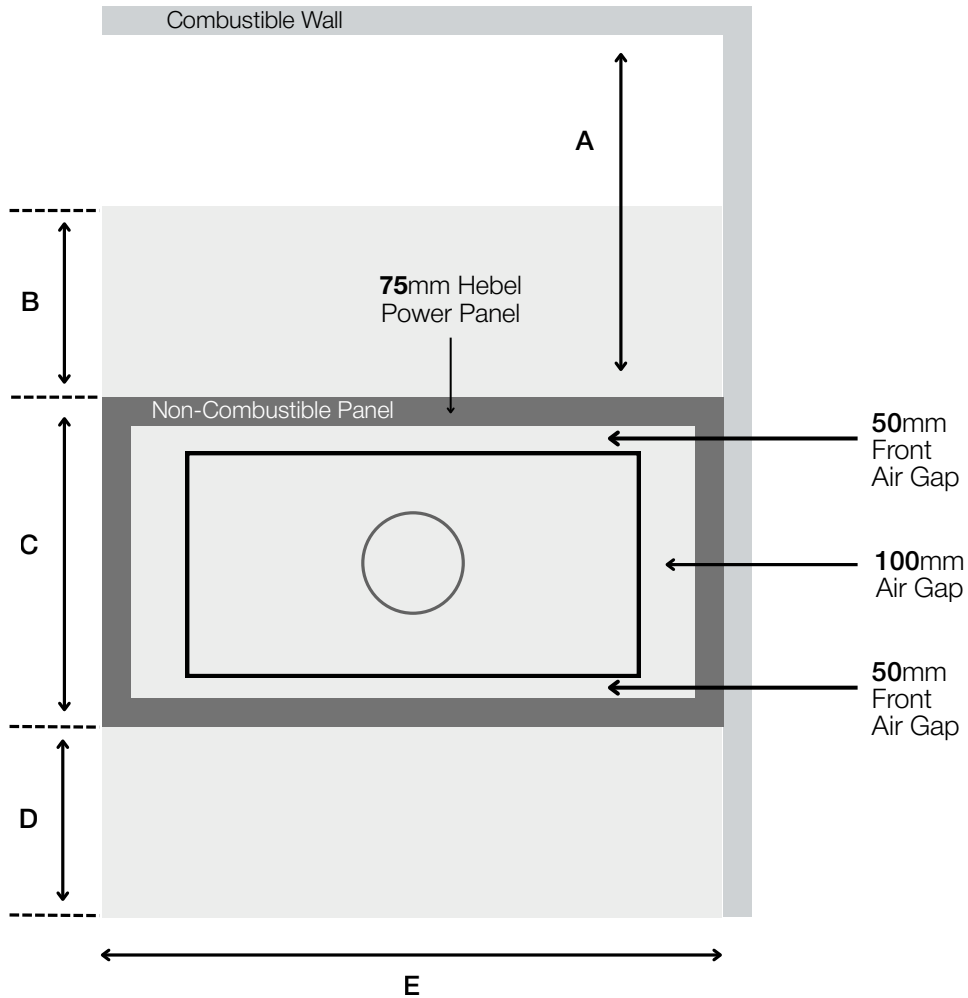

MODEL	A	B	C	D	E
FAS120 DS	1100	400	982	400	1533

**NOTE:** Measurements in mm. The above hearth dimensions apply to units installed with a leg height of 300mm or greater.

**CLAUSE:** A mantel shelf and mantel upright clearances were not tested and should be installed as per clause 3.4.1.3(b) of AS/NZS 2918:2018

**\*HEARTH:** The hearth must be a minimum of thickness of **75mm**

## 2 Preliminary Information

### **SAFETY NOTICE**

If this wood fireplace is not properly installed, this may result in a house fire. For your safety, follow the installation instructions, contact your local building, fire officials or authority having jurisdiction about restrictions and installation inspection requirements in your area.

The authority having jurisdiction should be consulted before installation to determine the need to obtain a permit.

### **IMPORTANT**

The licensed installer responsible for installing and certifying the appliance must also commission it and demonstrate its operation to the customer.

### **ALL PRELIMINARY INSTALLATION INFORMATION MUST BE READ PRIOR TO INSTALLATION**

### **MANDATORY INSTALLATION BY A LICENSED PROFESSIONAL**

Before any work begins, this appliance must be installed by a licensed/qualified professional in accordance with Australian and New Zealand Standards AS/NZS 2918:2018, as well as all applicable local and national regulations. The installer must follow the instructions and recommendations in this manual to ensure safe and proper operation. Failure to comply with AS/NZS 2918:2018 or improper use will void the manufacturer's warranty, which cannot be retained or assured in such cases.

### **CUSTOM INSTALLATION REQUIREMENTS**

Every installation is unique, and no two setups follow an identical procedure. It is essential to collaborate with a licensed installer, architect, and builder to design a custom installation suited to your specific requirements. A qualified and licensed trades professional must take all necessary precautions based on the technical aspects of each project. Failure to follow the assembly instructions in conjunction with AS/NZS 2918:2018 is the sole responsibility of the individual performing the work.

### **TECHNICAL INQUIRIES**

Further questions regarding your appliance and its installation should be directed towards your authorised stockist.

### **LIABILITY AND WARRANTY DISCLAIMER**

Any faulty assembly, improper use, installation of unauthorised components, or modifications to the appliance or its parts will result in compromised performance and potential safety hazards. The manufacturer/distributor assumes no liability for any resulting damage or injury, and all warranties will be immediately voided.

### **REFERENCE IMAGES AND SPECIFICATIONS**

All images and diagrams in this manual are for installation reference only and are not to scale. The manufacturer and distributor do not guarantee the accuracy of these images and accept no liability for discrepancies. These visuals serve as a guide in conjunction with written instructions and should not be used as standalone installation directives. The order of steps provided is a recommendation only.

*Sculpt Fireplaces Pty Ltd & Axis (Seguin Groupe) reserve the right to modify specifications without prior notice.*

# IMPORTANT

Prior to installation, unpack and inspect the appliance and all components for transport damage. Check the condition and operation of the glass, door/s, damper system and door locking mechanisms. Any damage must be reported to your local dealer within 10 days of purchase.

Combustible materials including timber framing, plasterboard, Fyrecheck or similar products must not be installed near or around the appliance unless specifically permitted within this manual and AS/NZS 2918:2018. Failure to comply may result in a non-compliant installation, fire hazard and voided warranty.

Electrical cables and components must not be placed near the appliance, as this may create a fire hazard.

Expansion and contraction may occur during heating and cooling cycles and are considered normal operation, not product defects.

External surfaces become extremely hot during operation and may remain hot after the fire has extinguished. Always use the supplied glove when operating the appliance.

Maintain all required clearances from combustible materials and never place or store items within the appliance's radiant heat zone.

For quality control purposes, some appliances may be supplied partially disassembled. Components including legs, firebricks and baffle plates may require on-site installation.

### **LIFT DOOR OPERATION**

This appliance is designed to operate as a slow combustion fireplace with the door/s closed during normal operation. The lift door function is intended for lighting and refuelling only. Do not operate this appliance with the door open.

### **CAUTION: BURN DRY, UNTREATED & SEASONED HARDWOOD ONLY**

This appliance is designed to burn natural wood only. Do not burn treated wood, oil-based wood, coloured paper, cardboard, coal, rubbish, garbage, tea tree, solvents, metal foils, plastics, waste materials, or any materials containing sulphur or oil. Burning these or similar materials may damage the appliance and may void the warranty.

### **DO NOT BURN**

- Oil Based Woods
- Coloured Paper
- Coal
- Trash
- Garbage
- Treated wood
- Cardboard
- Tea Tree
- Solvents
- Metal Foils

## 2 Preliminary Information

### **ROOM PRESSURE WARNING**

This appliance is not airtight and must never be installed in a room with negative pressure caused by range hoods, VMC systems, or other ventilation or heating appliances. Negative pressure can lead to poor combustion, smoke spillage, and safety risks. In well-insulated or airtight homes, ensure sufficient fresh air is available directly to the appliance.

### **COMBUSTION AIR**

The air supply, required for the proper operation of the appliance, must meet the minimum surface area and ventilation, as specified. It must be connected directly to outside or into a room ventilated to outside air, and connect directly onto the fireplace.

The external register must be protected by a permanent grid. Air inlet grids must be mounted to avoid blockage. During operation, this air inlet grid must be clear and not obstructed. Lack of combustion air will cause serious malfunctioning of the appliance

This appliance must not be installed on an air inlet serving another appliance. Possible pressure losses due to an excessively long flue should be taken into account (taken into consideration in sizing of the appliance and room installed in).

It is preferable to make the direct connection via an outdoor kit, in order to optimise combustion and performance of the unit. Based on the specific conditions of the building (airtightness, presence of a VMC system, presence of an extraction hood, etc.), it is compulsory to create an air inflow specific for the appliance. Ideally this air inflow must be created under the firebox.

It is important to recall that any further modification of conditions of use (installation of a VMC system, of an extraction hood or any other appliance that draws air, insulation works or improvement of airtightness, etc.) could cause smoke blow-back and adverse performance of the appliance.

### **PRE-INSTALLATION APPLIANCE PREPARATION**

Before installation, remove all packaging, protective materials, documentation, loose components, and accessories from inside and around the appliance. Check that all internal components, including baffle plates, firebricks, and other supplied parts, are correctly positioned and undamaged prior to installation and operation. Failure to remove packaging or correctly position components may result in appliance damage, unsafe operation, or excessive smoke and odour during initial use.

## 2 Preliminary Information

### **LOCATION**

Before the construction of the cavity, it is necessary to thoroughly and professionally examine the location of the appliance and the flue connection and penetration. It is also essential to take into consideration the appliance dimensions, the minimal opening dimensions in the casing specified in the "Installation Plan" chapter. and required air gap within the cavity

The appliance must be installed on a non combustible base with suitable load capacity, for the appliance, construction materials and fuel. If the existing building does not fulfil this precondition, it is necessary to adopt necessary measures for example, using a load distribution plate & structural reinforcement.

All preparatory work for appliance installation must be considered and concluded prior to installation (flue, outside air inflow, masonry, etc.). Dust caused by works can deposit on the appliance and burn during commissioning. It is recommended to wait until works are concluded to proceed to appliance installation. Ensure the appliance is free from dust and any materials prior to use.

### **HOT AIR TRANSFER REQUIREMENTS**

To distribute heat from the unit into the same or other rooms via hot air transfer kit, the duct MUST be 4 Zero type (aluminium inner core, aluminium outer, poly insulated, minimum R2.0) and tested to AS 4254.1-2012. vent MUST be metal. Hot air transfers are not required for all installations. If the top sections are left open, heat will naturally enter the wall cavity and flow into the room through the wall cavity vents.

It is forbidden to connect any hot air distribution system to the convection panel. If hot air distribution is provided through a system based on hood extraction, please follow the technical instructions provided by the manufacturer of the distribution system. If such a system is installed, however, it is necessary to retain the convection grills.

Note: Hot air transfer kits are not compatible with the FAS120 DS model.

## 2 Preliminary Information

### **EXPOSURE TO ELEMENTS**

Axis fireplaces are exclusively designed as indoor heating appliances, should the fireplace (or part there of ) be in contact with the outside elements including rain, snow, direct sunlight, excessive winds, etc; the damage sustained thereon will not be covered under the manufacturer or distributor warranty. Please consider prior to installing your fireplace exposed to outside elements.

Bad weather conditions can cause reverse draft or thermal blockage in the flue, particularly in case of foggy weather.

### **ACCEPTABLE VARIANCE ALLOWANCE**

Due to the production of these hand assembled and manufactured fireplaces, there is an acceptable allowance of 1-5mm variance of the unit and all it's components, including the door frame. This variance in production is non-claimable under any warranties.

### **HEAT RESISTANT MATERIALS**

Heat resistant materials must meet AS/NZS 2918:2018 clause 1.4.27 a material with an allowable service temperature of 600° Celsius or greater. Gyprock Fyrecheck is NOT a recommended heat resistant material and should not be used.

It is the users duty to make themselves aware of and apply all national or more restrictive local standards and regulations (AS/NZS 2918:2018).

### **ACCESS HATCH**

For ease of access for maintenance and potential technical intervention, the installation of an access hatch on the fireplace cavity is strongly recommended. Please note that Sculpt Fireplaces Ptd Ltd does not warranty any cost of installation, the inclusion of an access hatch at the time of installation can greatly assist in any technical intervention required.

#### **ACCESS HATCH EXAMPLE**

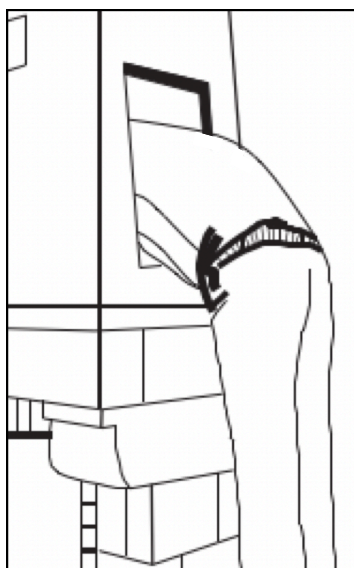

## 2.1 Leg Assembly

### LEG ASSEMBLY

IMPORTANT: This appliance must be installed using the leg extensions supplied with the unit. Under no circumstances is the appliance to be installed directly onto the floor or supporting structure without the provided legs and extensions fitted. The appliance must be installed to achieve a minimum clearance of **445mm** measured from the top surface of the hearth to the underside of the door opening.

Before commencing installation, ensure the floor or supporting structure is stable and capable of supporting the full appliance weight.

To streamline the installation process, it is recommended to pre-assemble each leg set prior to fitting them to the appliance. Each leg set consists of one flat angle bracket and one standard angle bracket. Confirm all components are present and correctly identified before proceeding with assembly.

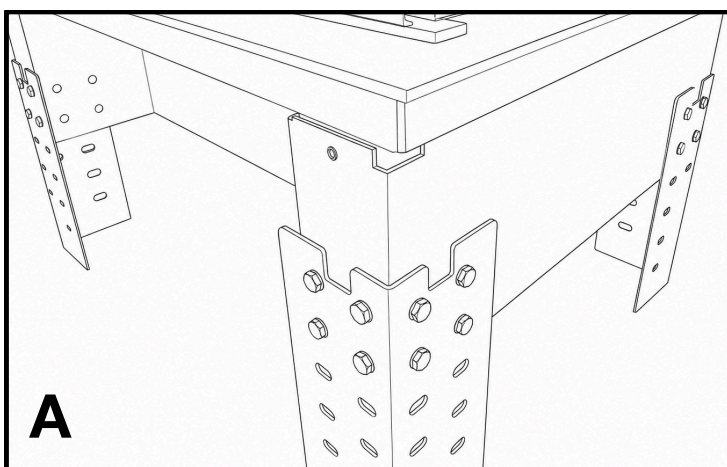
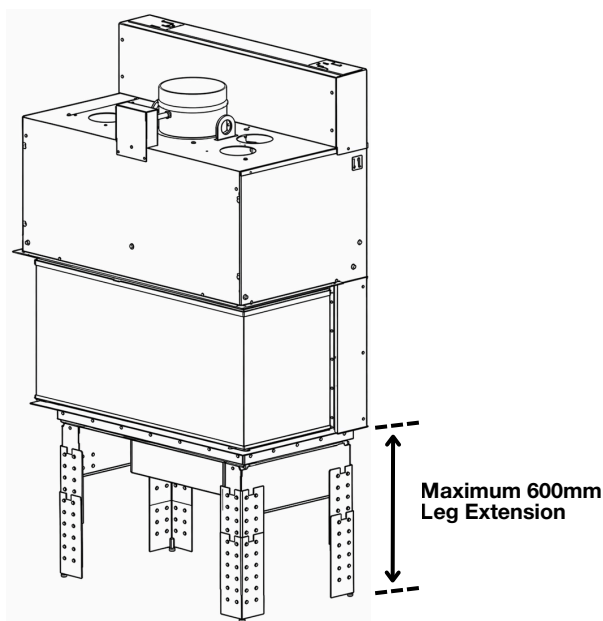

**Diagram A**

We recommend cross-fastening the nuts and bolts at each leg connection to ensure improved structural support and load distribution, using 2 x 4 bolts per leg connection (8 bolts total per leg).

## 2.2 Draft Adjustment Control

### DRAFT ADJUSTMENT CONTROL

The FAS120 Series fireplace is equipped with a single draft control that regulates the intensity of combustion. Moving the control towards the “+” position increases the airflow and combustion rate, while moving it towards the “-” position reduces the burn intensity for slower operation.

For optimal performance at nominal burn rate, position the control towards the closed (-) setting once the fire is well established.

Before opening the door to refuel, move the control to the “+” position to fully open the damper. This helps prevent smoke spillage into the room.

Always use the glove provided when operating the draft control or any other hot component of the appliance.

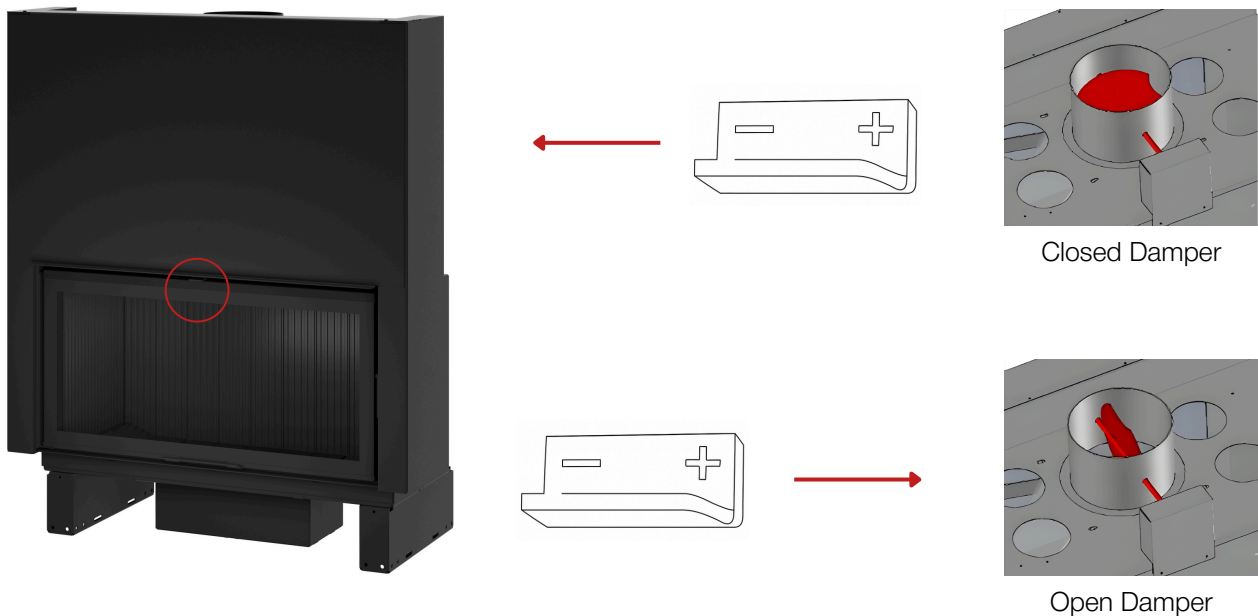

## 2.3 Hot Air Transfer Kit

### HOT AIR TRANSFER KITS

Axis fireplaces are designed with a convection casing that houses one or more heat exchangers, allowing heat to be distributed to other areas of the home via ducting. A heat transfer ducting kit can be connected directly to the top of the firebox casing.

- **Ducting requirements:** The duct must be 4 Zero type (aluminium inner core, aluminium outer, poly insulated, minimum R 2.0) and tested to AS 4254.1-2012. The outlet must be metal.
- **Performance:** Heat transfer works best over distances up to 6 m via natural convection. The use of an inline fan is not recommended.
- **Optional installation:** Hot air transfer kits are not required for all installations. If the top sections are left open, heat will naturally enter the fireplace cavity and flow into the room through the fireplace cavity vents.
- **Prohibited connections:** Do not connect any hot air distribution system to the convection panel. If hot air distribution is provided via a hood extraction system, follow the manufacturer's technical instructions and retain the convection grilles.

Note: Hot air transfer kits are not compatible with the FAS120 DS model.

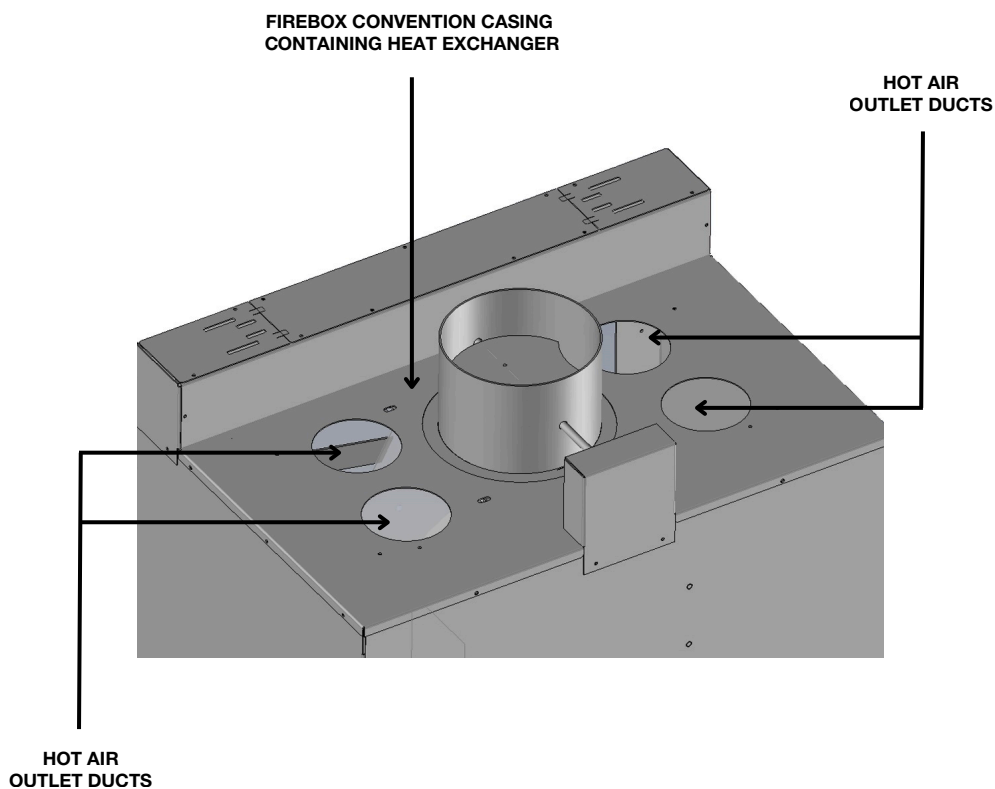

## 2.4 Outdoor Air

### OUTDOOR AIR SPIGOT POSITION

MODEL	SPIGOT POSITION
FAS120 SS	Rear
FAS120 DS	Side
FAS120 VL	Rear
FAS120 3V	Rear

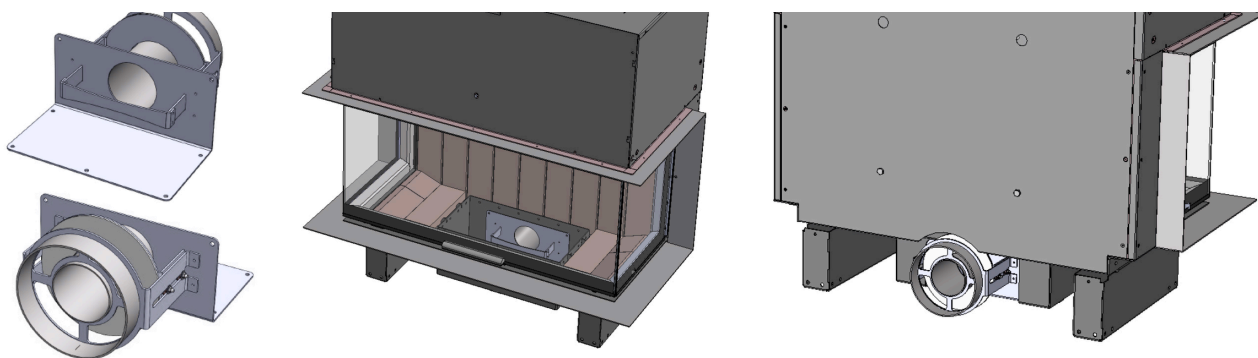

Our patented AIR CONNECT system allows for primary air supply with a single connection. Even better, the indirect air supply can be shut off during periods of inactivity, preventing the surround from getting cold. And all of this can be adjusted via the ash pan compartment.

**Note: An additional indirect fresh air supply may be required when installed in homes rated 6 stars or above.**

## 2.5 Ash Grate

### ASH GRATE - INSTALLATION

The FAS120 Ash Grate are made up of a single part. The ash grate is put into position by slipping it into the support profile above the ash pan.

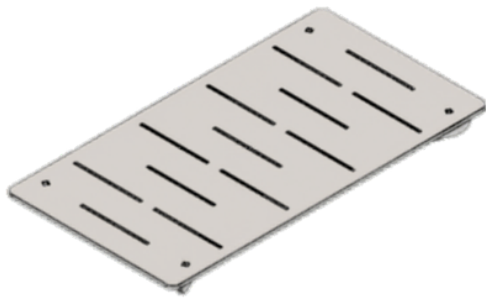

TOP VIEW

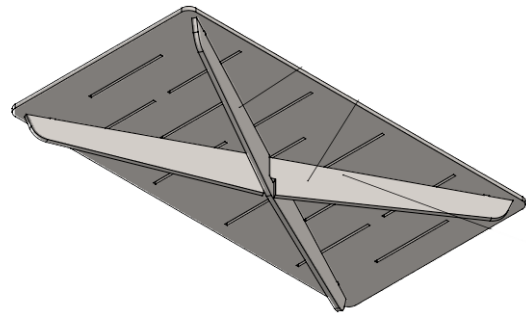

BOTTOM VIEW

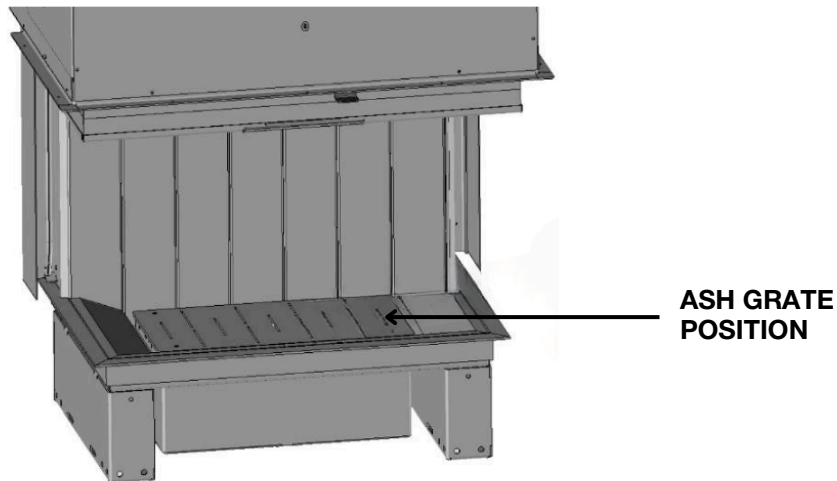

## 2.6 Baffle Plates and Flue Requirements

### BAFFLE PLATES

Baffle plates are required to protect the top of the firebox from the intensity of the fire. They also help redirect heat back into the room. Baffle plates also assist by burning off carbon particles and therefore decreasing the emissions produced.

Baffle plates are supplied separately and must be installed before use. Once the baffle plates are placed into position (usually by the installer) they should be left alone. Only a licensed and experienced technician should remove or adjust baffle plates during maintenance. Ensure all baffle plates are installed before lighting your fireplace. Burning your fireplace without these in place can cause irreparable damage and void your warranty.

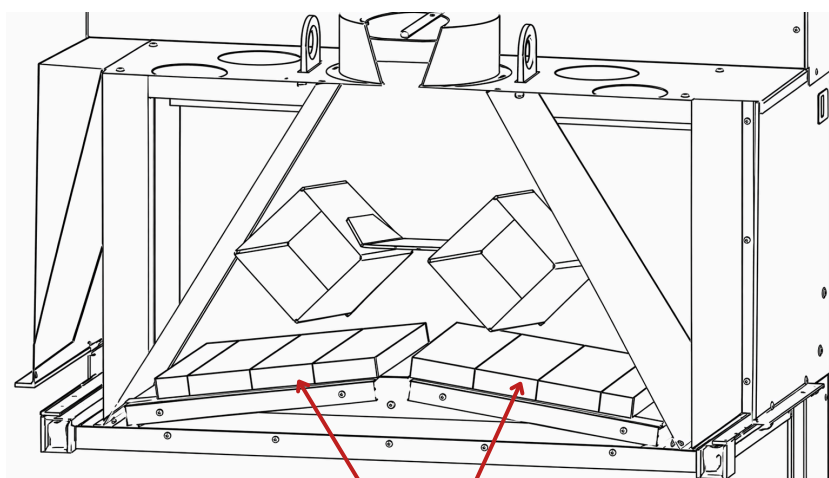

*Baffle plates in position*

### NEW ZEALAND COMPLIANCE

For installations in New Zealand, an additional baffle plate must be fitted to comply with local standards. The additional baffle plate must be installed centrally between the existing baffle plates to fully close and seal the gap. Contact Sculpt Fireplace Collection for further information

---

### THE FLUE CONNECTION

Any flue connection must have at least the internal diameter of the appliance smoke flue outlet. Under no circumstances is the flue to be manipulated with adaptors, reducers or similar products that change the flue sizing. The maximum number of bends on the flue connection is two, each of a maximum of 45°. It is strongly recommended to make the flue connection as simple and straight as possible. The unit's installation depends on the available flue connection path.

# INSTALLATION GUIDE

This guide provides a detailed, step-by-step process for installing the unit, ensuring a safe and compliant setup. It applies to both brick and Hebel installations, covering essential requirements such as clearances, air gaps, and structural considerations.

Follow each step carefully to ensure proper ventilation, stability, and performance. Refer to the provided diagrams for connection options and specific measurements relevant to your model. Always check that all components, including legs and air gaps, are correctly installed before proceeding to the next step.

FRONT VIEW

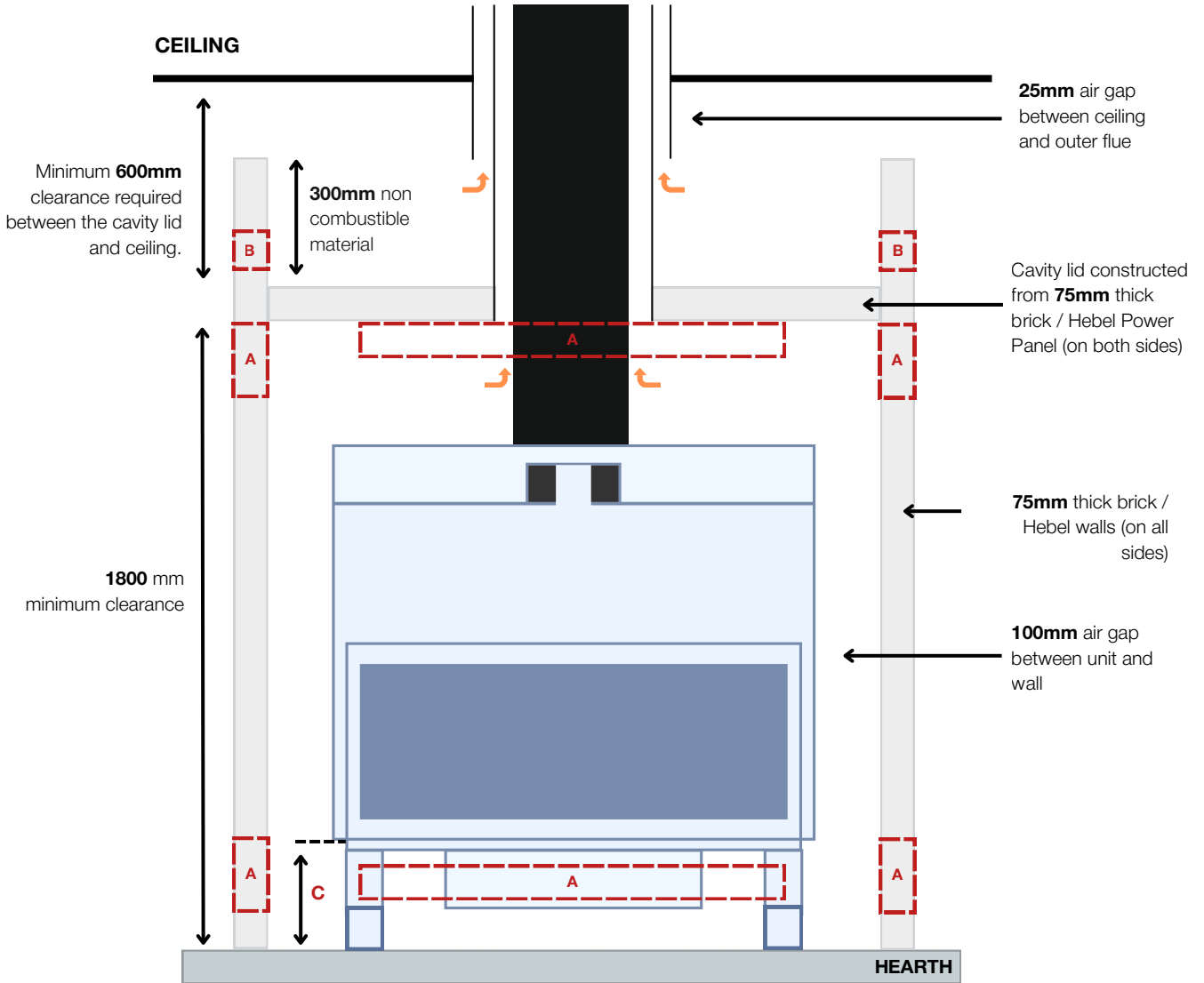

<p><b>A</b> Suggested location of cavity ventilation grilles**</p>	<p>* See product specifications for clearances, hearth size, and thickness. ** 65,000 mm<sup>2</sup> venting minimum.</p>
<p><b>B</b> Decompression Grid</p>	<p>*2,000mm<sup>2</sup> Vent Size Only required when cavity is closed above ceiling height</p>
<p><b>C</b> Appliance Height</p>	<p>The appliance must be installed with the legs positioned to achieve a height of 445mm from the door opening to the top surface of the hearth.</p>

**NOTE:** The above diagram is for reference only, Sculpt Fireplaces Pty Ltd and Seguin Groupe bear no responsibility or liability to the interpretation of this drawing

### SIDE VIEW

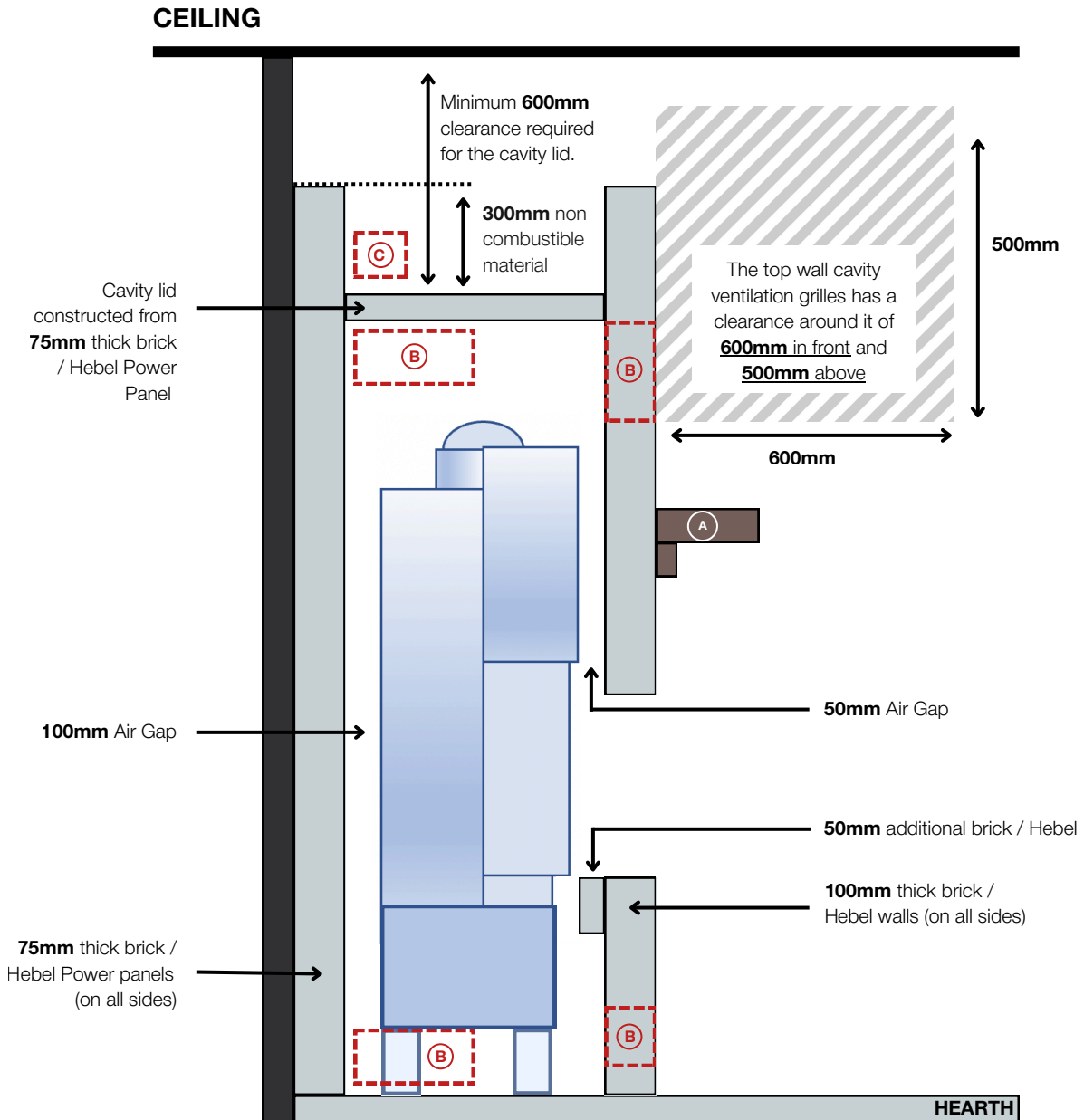

**A** Optional combustible mantle

\* Not Tested refer to clause 3.4.1.3(b) of AS/NZS2918:2018

**B** Suggested location of cavity ventilation grilles\*\*

\* See product specifications for clearances, hearth size, and thickness.

\*\* 65,000 mm<sup>2</sup> venting minimum.

**C** Decompression Grid

\*2,000mm<sup>2</sup> Vent Size

Vents are required if the area is enclosed. If the ceiling in this area is removed, decompression vents are not required.

**NOTE:** The above diagram is for reference only, Sculpt Fireplaces Pty Ltd and Seguin Groupe bear no responsibility or liability to the interpretation of this drawing

### TOP VIEW

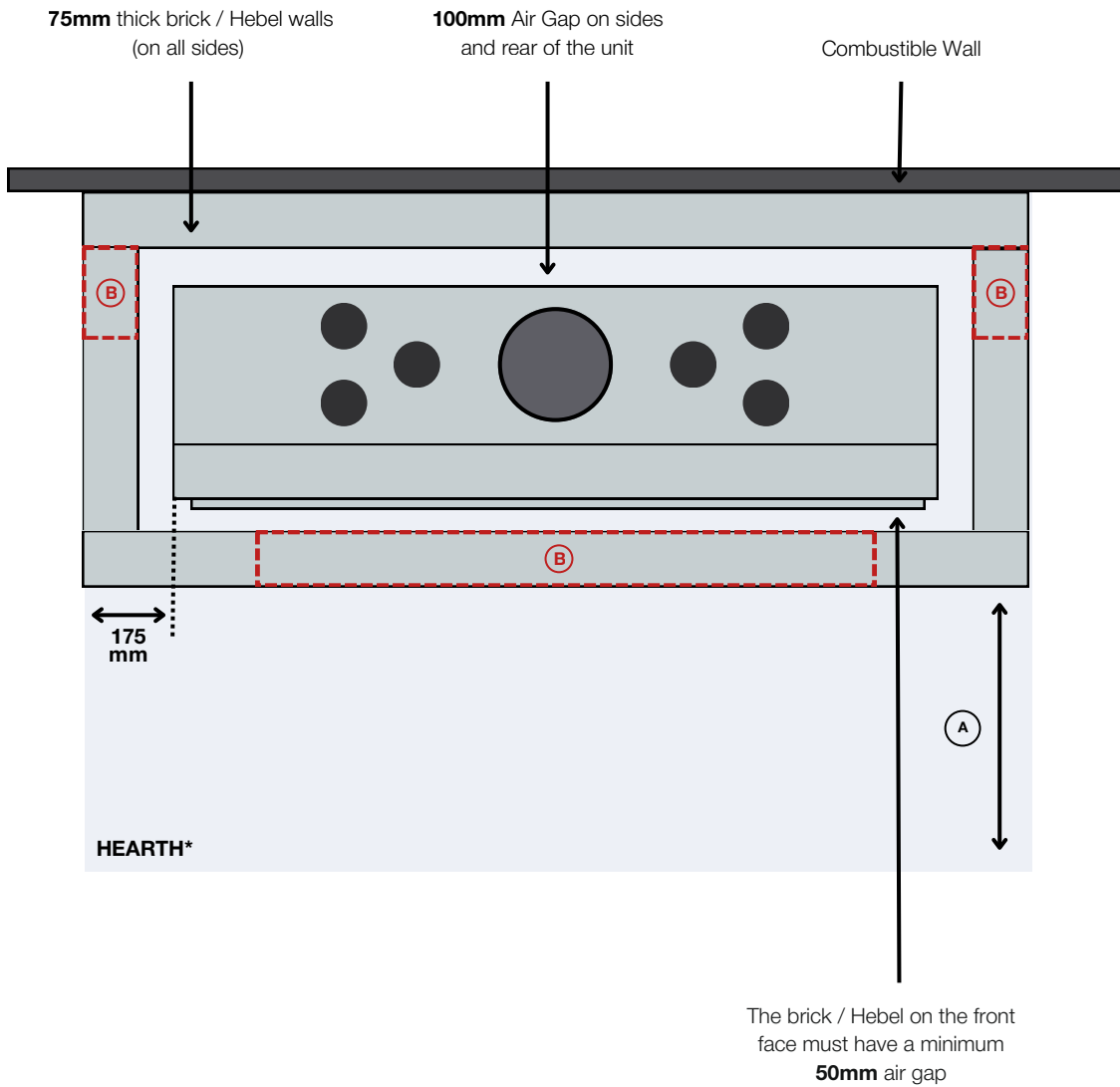

**A** Hearth dimensions vary by model.

**B** Suggested location of cavity ventilation grilles\*\*

\* See product specifications for clearances, hearth size, and thickness.

\*\* 65,000 mm<sup>2</sup> venting minimum.

**NOTE:** The above diagram is for reference only, Sculpt Fireplaces Pty Ltd and Seguin Groupe bear no responsibility or liability to the interpretation of this drawing

The above information is relevant to the following Axis models: FAS120 SS.

### TOP VIEW

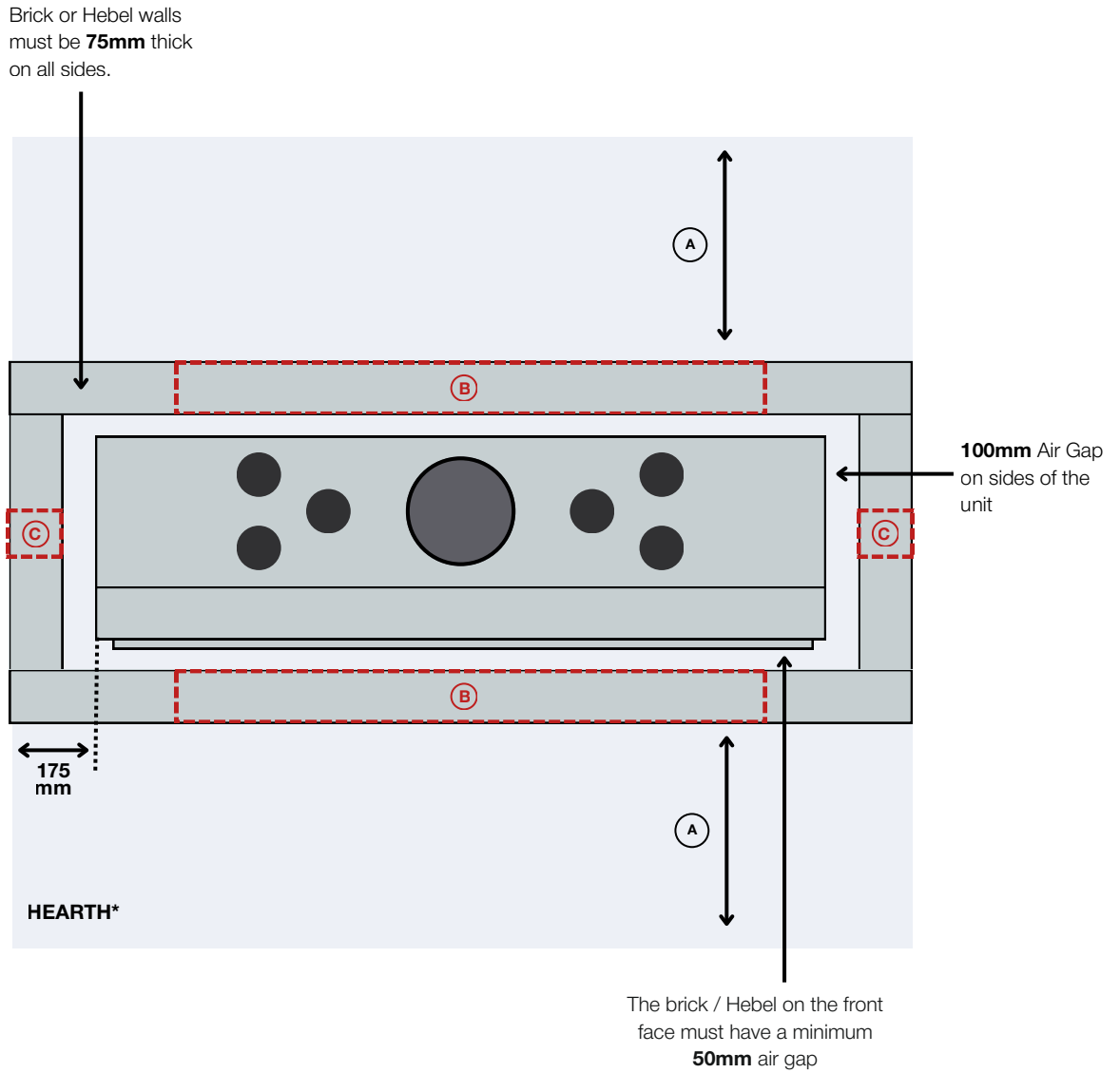

<p><b>A</b> Hearth dimensions vary by model.</p> <p><b>B</b> Suggested location of cavity ventilation grilles**</p>	<p>* See product specifications for clearances, hearth size, and thickness.</p> <p>** 65,000 mm<sup>2</sup> venting minimum.</p>
<p><b>C</b> Decompression Grid</p>	<p>*2,000mm<sup>2</sup> Vent Size. Only required when cavity is closed above ceiling height</p>

**NOTE:** The above diagram is for reference only, Sculpt Fireplaces Pty Ltd and Seguin Groupe bear no responsibility or liability to the interpretation of this drawing

The above information is relevant to the following Axis models: FAS120 DS.

### **DOUBLE SIDED FIREPLACE INSTALLATION**

All double sided fireplaces are designed for internal walls only. Wall cavity ventilation vents are required to be on top and bottom and sized at 65,000mm<sup>2</sup> each to ensure pressure equilibrium across both rooms and ensure correct draught inside the fireplace.

These fireplaces have been purposely designed and have a Primary and Secondary door. The Primary door is on the same side as the Flue Damper control. The Primary door should be located in the room closest to the firewood storage and loading location.

It is critical that the installing technician determine the correct orientation of the double sided fireplace to ensure proper use. Loading firewood via the Secondary door may cause smoke leakage through the Primary door.

### **IMPORTANT**

**While it is possible to install a double-sided appliance for internal/external applications, doing so will void all appliance warranties.**

### FRONT VIEW

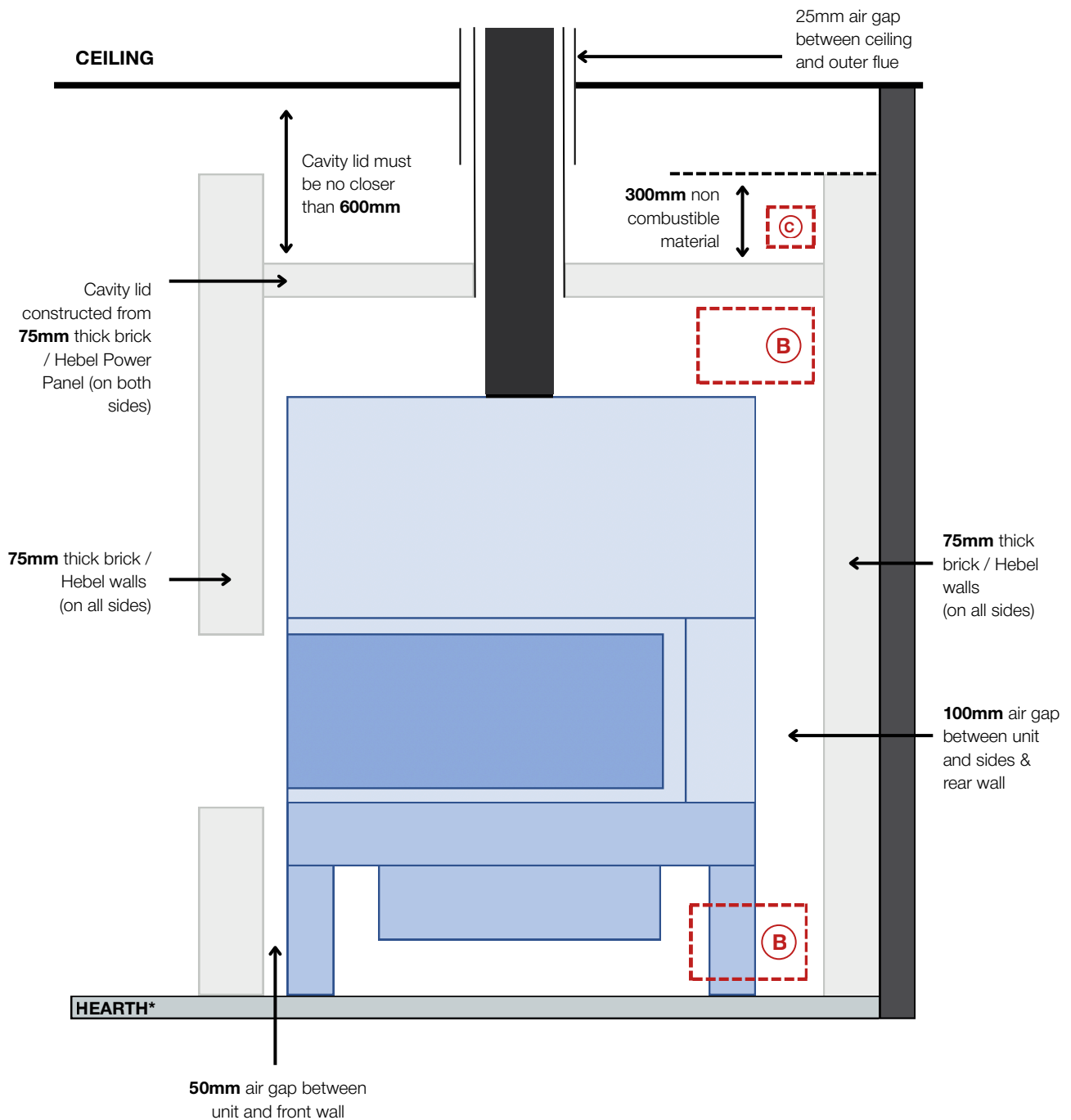

**(B)** Suggested location of cavity ventilation grilles\*\*

\* See product specifications for clearances, hearth size, and thickness.  
 \*\* 65,000 mm<sup>2</sup> venting minimum (each).

**(C)** Decompression Grid

\*2,000mm<sup>2</sup> Vent Size.  
 Only required when cavity is closed above ceiling height

**NOTE:** The above diagram is for reference only, Sculpt Fireplaces Pty Ltd and Seguin Groupe bear no responsibility or liability to the interpretation of this drawing

The above information is relevant to the following Axis models: FAS120 VLD and FAS120 VLG

### TOP VIEW

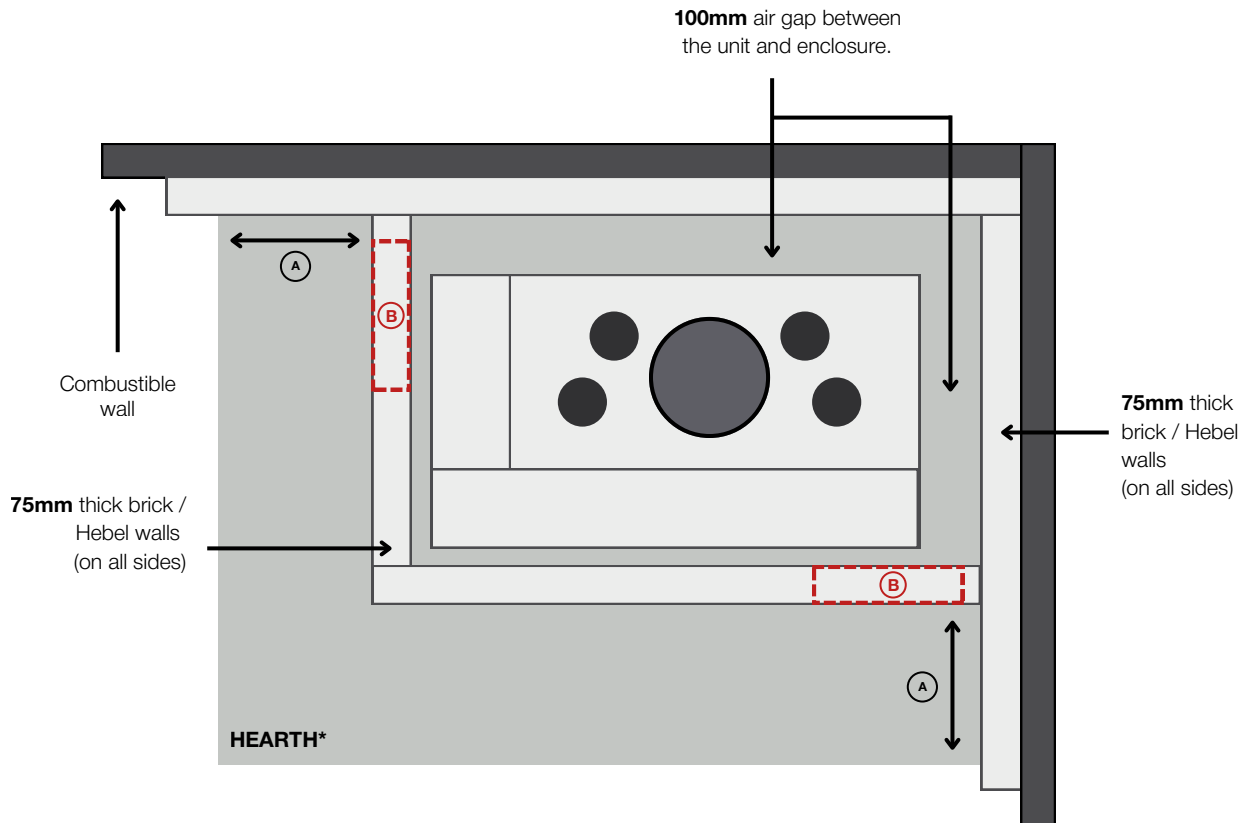

**A** Hearth dimensions vary by model.

**B** Suggested location of cavity ventilation grilles\*\*

\* See product specifications for clearances, hearth size, and thickness.

\*\* 65,000 mm<sup>2</sup> venting minimum.

**NOTE:** The above diagram is for reference only, Sculpt Fireplaces Pty Ltd and Seguin Groupe bear no responsibility or liability to the interpretation of this drawing

The above information is relevant to the following Axis models: FAS120 VLG and FAS120 VLD.

### FRONT VIEW

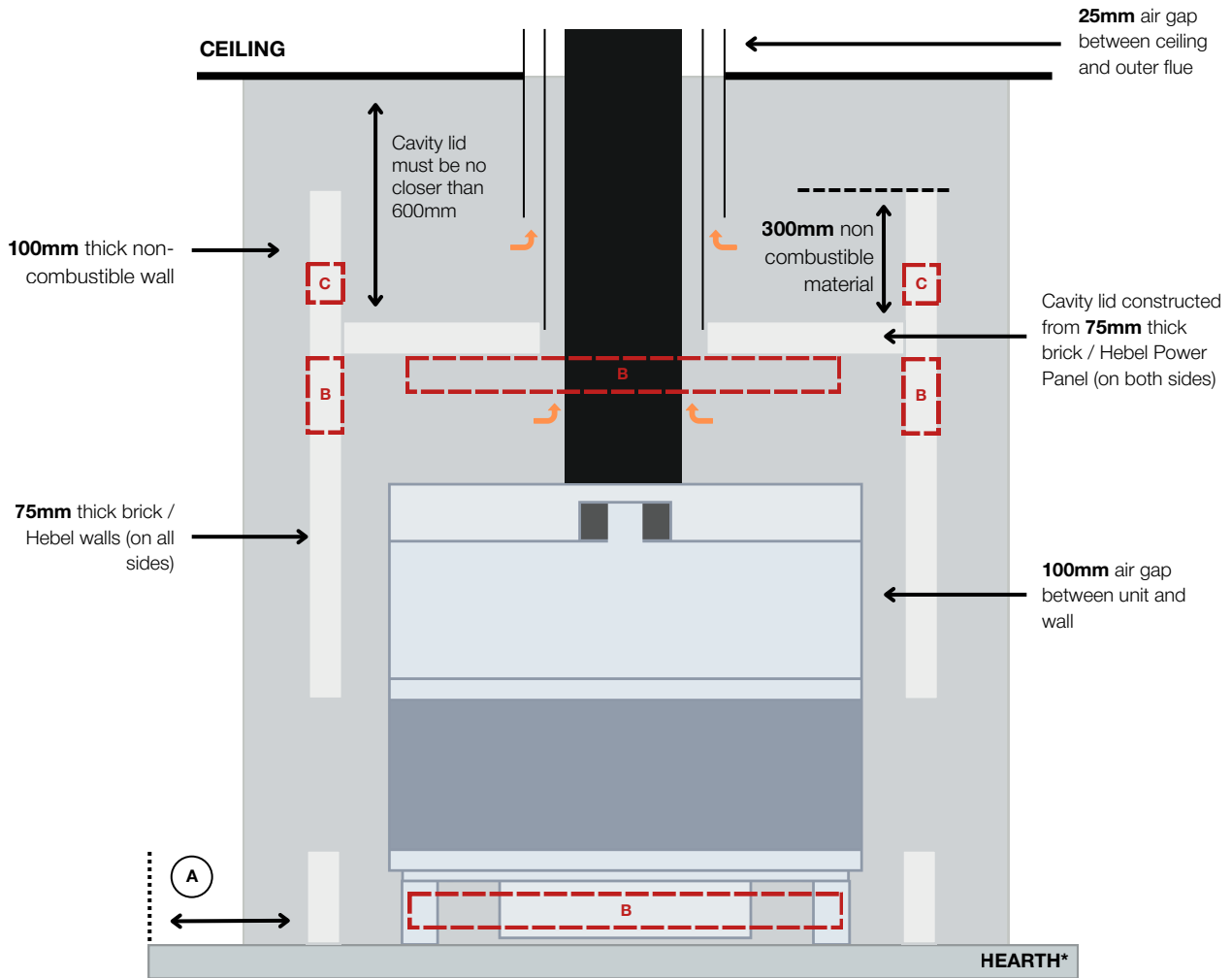

<p><b>A</b> Hearth dimensions vary by model.</p>	<p>See product specifications for clearances, hearth size, and thickness.</p>
<p><b>B</b> Suggested location of cavity ventilation grilles**</p>	<p>** 65,000 mm<sup>2</sup> venting minimum.</p>
<p><b>C</b> Decompression Grid</p>	<p>*2,000mm<sup>2</sup> Vent Size. Only required when cavity is closed above ceiling height</p>

**NOTE:** The above diagram is for reference only, Sculpt Fireplaces Pty Ltd and Seguin Groupe bear no responsibility or liability to the interpretation of this drawing

The above information is relevant to the following Axis models: FAS120 3V

### TOP VIEW

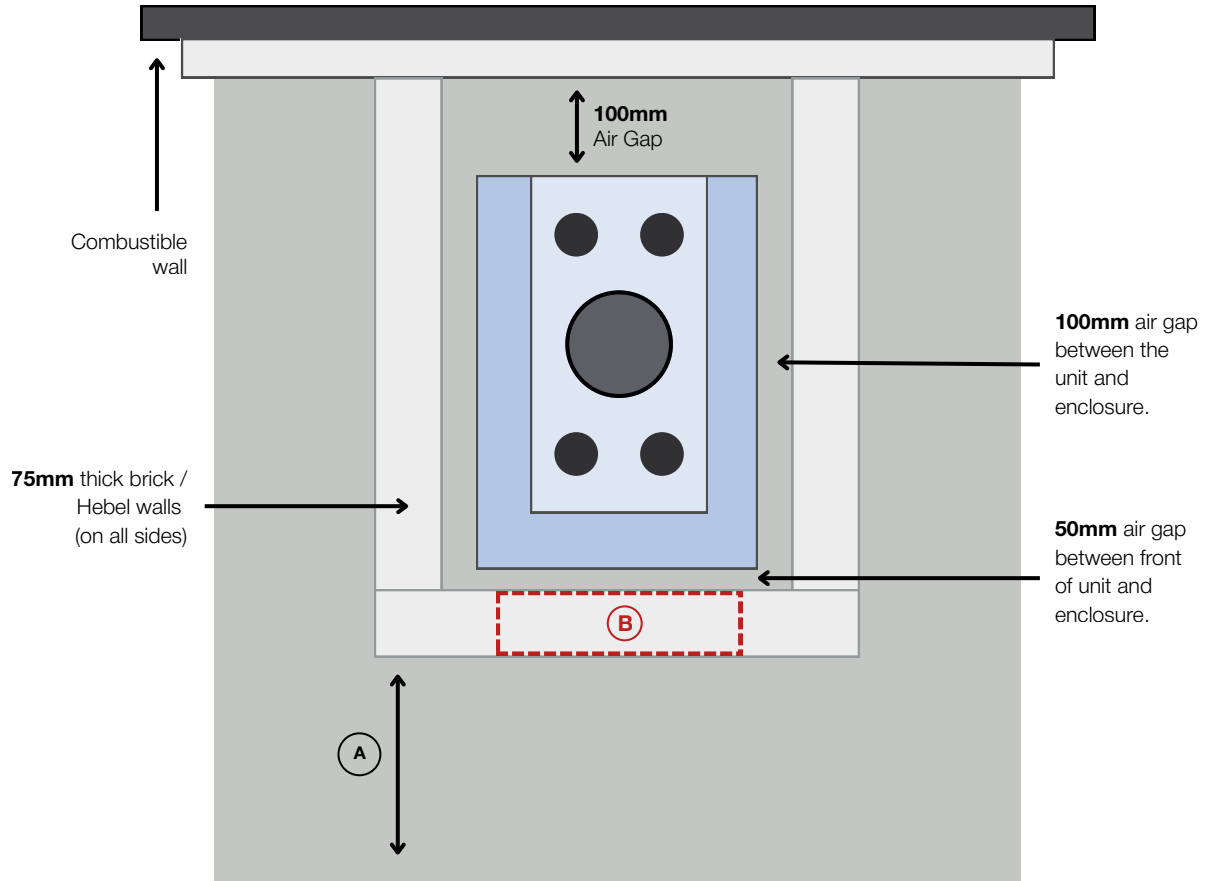

**A** Hearth dimensions vary by model.

**B** Suggested location of cavity ventilation grilles\*\*

\* See product specifications for clearances, hearth size, and thickness.

\*\* 65,000 mm<sup>2</sup> venting minimum.

**NOTE:** The above diagram is for reference only, Sculpt Fireplaces Pty Ltd and Seguin Groupe bear no responsibility or liability to the interpretation of this drawing

The above information is relevant to the following Axis models: FAS120 3V.

## 3.5 Installation Guide

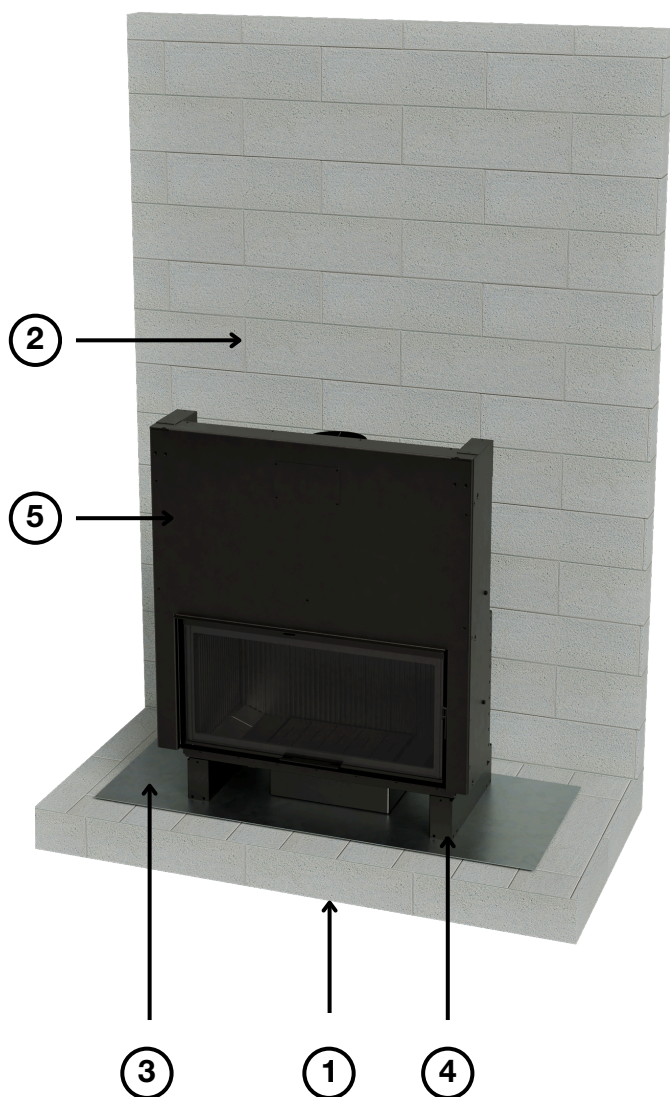

### **STEP 1 : BASE**

Install a non-combustible base, at least 75mm thick, using either solid bricks or Hebel. Ensure it is positioned on stable, level ground capable of supporting the unit's weight.

### **STEP 2 : BACK WALL**

Construct a non-combustible back wall using brick or Hebel, extending from the base to the ceiling (1.8m).

### **STEP 3 : SHEET METAL LAYER (OPTIONAL)**

Place a thin sheet metal layer on top of the brick or Hebel base to level the surface and facilitate safe manoeuvring of the firebox.

### **STEP 4 : LEGS ASSEMBLY**

If the unit requires elevation, install and secure the appliance legs at this stage, ensuring they are properly adjusted and fixed in place.

### **IMPORTANT**

- Refer to the appliance legs installation guide on page 15.

### **STEP 5 - POSITIONING THE UNIT**

Place the firebox into position on top of the sheet metal. Ensure there is a 100mm air gap on all sides and 50mm air gap underneath the firebox.

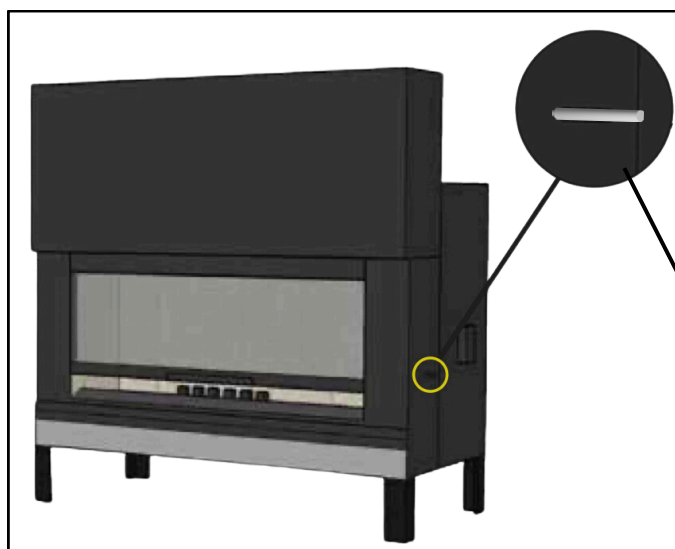

### **IMPORTANT : RELEASING GLASS DOOR**

Prior to continuing with installation, ensure to release the glass door. First remove screws located on either side of the unit, then proceed to slowly lower the door from its factory position. Test to ensure there is smooth operation both up and down.

This is located in the rear of the heater for the FAS120 3V Model.

## 3.5 Installation Guide

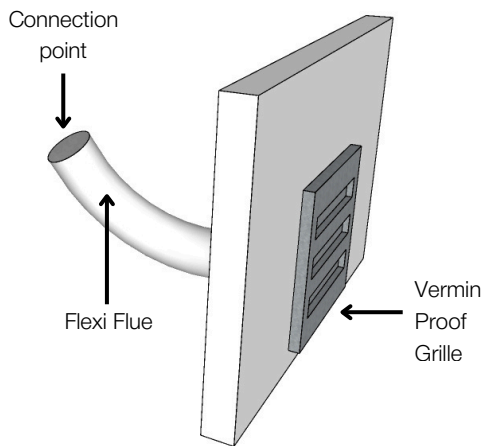

### **STEP 6 : OUTDOOR AIR KIT (OPTIONAL STEP)**

Inadequate fresh air in the room can cause smoke spillage and reduce fireplace efficiency. For homes rated 6+ star, BAL (Bushfire Attack Level), or those with air-extracting devices like fans or range hoods, installing an Outdoor Air Kit is strongly recommended.

#### **INSTALLATION STEPS:**

- The adaptor is already in position at the bottom of the unit.
- Fit 125mm flexi flue onto the outdoor air connection point and secure with a Tek screw.
- Run flexi flue to the outside wall and attached adapter piece and fit vent on the outside.
- Secure the metal vermin-proof grille to the outside wall.
- Calculate the required length of the flexi flue according to the ventilation requirements of the cavity and room.



### **STEP 7 : TRIM (OPTIONAL)**

#### **IMPORTANT**

Trim must be fitted onto the firebox PRIOR to installing the front of the enclosure.

- Manoeuvre the trim on the front of the firebox.
- On the side of the façade of the firebox, drill two holes at 4.2mm.
- The holes must match with the slotted holes on the trim
- Manoeuvre the trim into desired position.
- Fix the trim into place using M5 screws & washers (not provided).

### **STEP 8 : FIRST FLUE LENGTH**

Place the first single skin length of flue (with no crimp ends) around the outside of the spigot. You may also use a heat resistance sealant (i.e. Firecork) to seal any air gaps.

## 3.5 Installation Guide



### **STEP 9 - SIDE WALLS**

Construct a continuous layer of bricks or Hebel on each side of the firebox, extending from the base up to the ceiling. Ensure you leave a uniform 100mm air gap on the rear and sides of the firebox to maintain proper insulation.

All enclosure joints must be sealed correctly to ensure they do not allow heat to escape from the cavity enclosure.

### **IMPORTANT**

If you are installing your appliance with side vents please allow for the vent openings in the cavity exterior.

- The vents must be installed above and below the appliance.
- The enclosure must be vented to a total area of 65,000 mm<sup>2</sup>.
- Maintain a clearance of 600mm in front and 500mm above each vent from any combustible materials.

### **STEP 10 - CAVITY LID**

The cavity lid must be installed no closer than 600mm to the ceiling and should be constructed using:

- Minimum 3mm thick steel plate for support
- 12mm thick heat-resistant sheet
- 1 x 25mm Rockwool sheet with a central hole for the active flue.

Or

- 75mm Hebel Powerpanel

You may use a heat-resistant sealant (e.g., Firecork) and heat-proof tape to seal any air gaps. It is essential that the cavity lid is fully sealed along all edges.

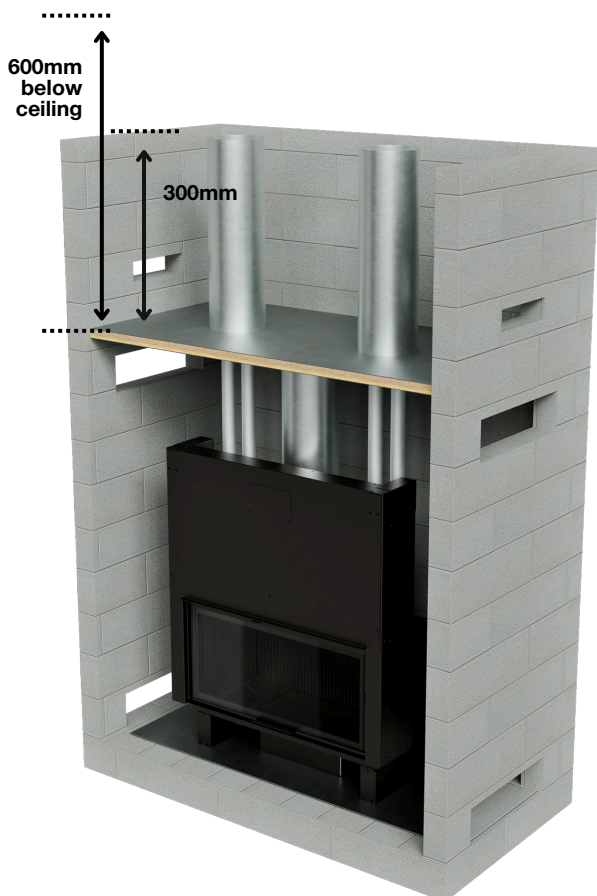

### **IMPORTANT**

To ensure optimal and even distribution of airflow around your appliance, follow these recommendations based on vent placement:

### **FRONT & SIDE VENTS**

It is highly recommended the cavity lid be installed flat to ensure sufficient air flow around the appliance when vents are used.

## 3.5 Installation Guide



### **STEP 11 - HEAT TRANSFER**

(OPTIONAL STEP)

The duct **MUST** be 4 Zero type (aluminium inner core, aluminium outer, poly insulated, minimum R2.0) and tested to AS 4254.1-2012. The vent **MUST** be metal.

See page 17 for hot air transfer kit requirements and additional information

Cut a hole in the lid of the enclosure nearest to the room where the heat is to be transferred. Run the ducting from this hole into the roof space and locate to the desired room, cut out the plaster and install a metal register into the ceiling of the desired room.

If more ducts are required additional components and duct design is to be provided by the retailer or installer.

### **IMPORTANT**

A maximum duct run of 6m total length is recommended. A maximum of four ducts can be run off the Axis FAS120 models.



### **STEP 12 - TRIPLE SKIN FLUE**

Continue Triple Skin Flue through and above the cavity lid. The lower end of the triple skin casing should be close fitting against the lid and the outer casing must be ventilated.

Air vents on the first length of triple skin flue must be cut, or manufactured into the bottom length of the flue as per testing.

### **STEP 13 - MANTLE**

(OPTIONAL STEP)

In the instance of a mantle shelf installation refer to 3.4.1.3(b) of AS/NZS2918:2018.

# 3.5 Installation Guide

## EXTERIOR FLUE DIAGRAM AND CLEARANCES

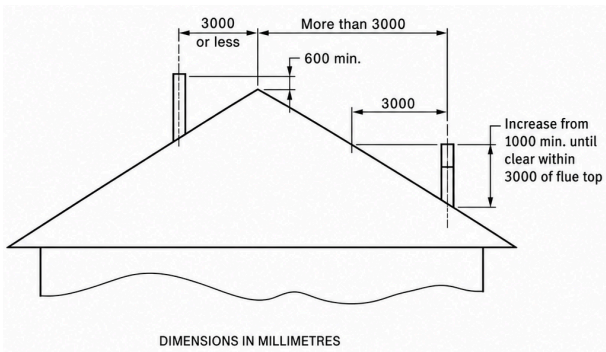
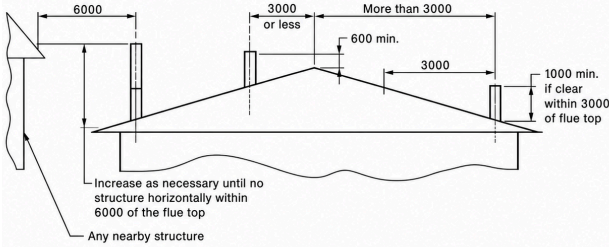

### **STEP 14 - FLUE PENETRATION**

Extend the Triple Skin Flue into the roof cavity, and above the roof line as per AS/NZ 2918:2018.

There must be a minimum of 25mm clearance around the outer triple skin flue. The flue must extend a minimum of 1m above the roof line and have a 3m diameter clearance from the top of the cowl to any objects in a horizontal direction as per AS/NZ 2918:2018.;

### **IMPORTANT**

Please note that the flue should not include more than two 45° bends. Each bend must be limited to 45°, with no more than one 1000mm section of flue between bends.

### **STEP 15 - FRONT WALL**

Construct the front wall with masonry bricks / Hebel or a layer of 12mm minimum thick heat resistant sheet. An air gap is required in front of the appliance.

### **STEP 16 - VENTILATION**

For side ventilation, refer to step 9 on page 33.

### **IMPORTANT**

Ventilation is required to assist with air circulation.

To ensure proper air circulation, at least two intake grills **MUST** be installed at the bottom (75mm above the floor) and two out-take grills **MUST** be installed at the top under the Hebel cap. Vents must be constructed with non-combustible materials.

Each vent must be a minimum of 800mm wide x 75mm high, totally 65,000mm<sup>2</sup> in size.

\*The vent sizes and quantity can be adapted and changed BUT they must meet the minimum ventilation requirements as specified above. For custom vent sizing please contact your nearest stockist.

## 3.5 Installation Guide



### **STEP 17 - HEARTH**

The hearth must be constructed from a non combustible material and must extend in front of and either side any part of the appliance.

Refer to section 1.2 for Hearth requirements specific to each model.

### **STEP 20 - BAFFLE PLATES**

Ensure the baffle plate(s) are securely in place within the appliance, as this step is critical for both safety and proper operation.

## 3.6 Commissioning Checklist

To ensure the fireplace is installed correctly, the installer must complete all checklists

### FIREPLACE

The fireplace is installed as per AUS/NZ2918:2018	
All components are present (refer to page 25)	
Baffles are in place	
Flue Damper Control is operational	
Door locking bolts removed and the door lifts up and down smoothly	
All moveable components move with ease (ie- air slides and handles)	
Door(s) unlatch fully and correctly for maintenance	
No combustible materials left in firebox or ash pan	
Smoke test has been performed and passed	
Operational Instructions given and explained to Customer	

### WALL CAVITY

Floor protector abides by required thickness	
Cavity walls are constructed of 100mm thick Hebel or equivalent	
Required amount of Cavity Ventilation Grilles installed at correct height	
There are no air gaps in wall cavity apart from convection grilles and flue venting	
No combustible materials are inside the wall cavity	

# 3.6 Commissioning Checklist

## FLUE

All flue is installed as per AUS/NZ2918:2018	
Flue is a minimum of 5.4m high from the hearth to the cowl	
Flue system and cowl are securely installed and supported along the full length of the flue run.	
Second skin is vented from the wall cavity to cowl	
Third skin is vented from above wall cavity to cowl	
Abides by all clearances	

## OUTSIDE WALL CAVITY

Combustible Mantle (if installed) abides by guide (see page 28 for reference)	
Hearth is installed in front of all faces, and abides by guide (refer to section 1.2)	
Ensure no combustible materials are within 1200mm of any face of the fireplace	
Cavity Ventilation Grilles are non-combustible and not obstructed	

**Installed By:** .....

**Date:** .....

**Unit Model:** .....

**Serial Number:** .....

**Compliance Certificate:** .....

# USER GUIDE

This guide provides comprehensive information on the safe operation, routine maintenance and ongoing care of your new appliance. It is designed to help you achieve optimal performance, maximise efficiency and extend the lifespan of the appliance over time.

Within this guide, you will find instructions on correct operation, fuel usage, cleaning procedures, and recommended maintenance intervals, along with important safety considerations.

Please read each section carefully before operating the appliance and retain this guide for future reference.

## USING YOUR APPLIANCE

To assist you and help you get the most out of your appliance, we invite you to watch the video below, it shows good and bad practices.



## FAILURES AND REMEDIES

ISSUES	TROUBLESHOOTING STEPS
Soiling of the Glass Backflow when opening the door Condensation Corrosion	<ul style="list-style-type: none"> <li>• Burn wood with humidity &lt;20%</li> <li>• Increase the combustion air supply*</li> <li>• Check the air supply settings of the appliance</li> <li>• Clean the appliance</li> <li>• Check the frequency of chimney sweeping (twice a year, including once during the period of use).</li> <li>• Clear the flue outlet of any disturbing element*</li> <li>• Raise the cap on the smoke outlet*</li> <li>• Raise the flue (40cm above the Ridge)*</li> <li>• Insulate the flue*</li> </ul>
Wood is hard to burn	<ul style="list-style-type: none"> <li>• Use wood with a smaller section or in quarters</li> <li>• Put at least two logs (with the exception of densified logs)</li> <li>• Burn wood with humidity &lt;20%</li> <li>• Increase the combustion air supply*</li> <li>• Clear the flue outlet of any disturbing element*</li> <li>• Raise the cap on the smoke outlet*</li> <li>• Raise the flue*</li> </ul>
The wood burns too fast	<ul style="list-style-type: none"> <li>• Put logs of larger section</li> <li>• Check the presence of baffle plates in the appliance*</li> <li>• Check the air supply into the appliance*</li> <li>• Install a draft moderator*</li> </ul>
Room Smoking / Blocked Flue (Creosote)	<ul style="list-style-type: none"> <li>• Burn wood with humidity</li> <li>• Increase the combustion air supply</li> <li>• Clear the flue outlet of any blockage*</li> <li>• Increase flue length*</li> </ul>

*\*This operation is to be carried out by a qualified professional.*

### DOOR OPENING (LIFTING)

**WARNING: The combustion chamber must always remain closed, except during reloading, in order to prevent smoke blowback.**

This appliance has not been designed to operate with its door open.

The door opening of the FAS120 models takes place in two phases:

1. A standard up-down phase that provides an opening sufficient to load wood in the appliance.
2. A phase where it is possible to exert pressure on the joints using the panel.

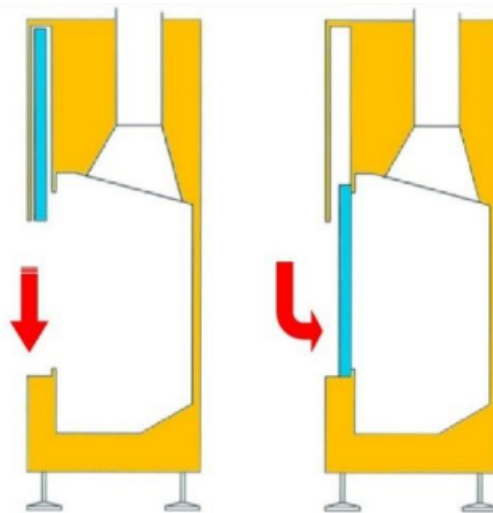

### LIGHTING THE FIRE AND RELOADING

The appliance must be lit according to the reverse fire lighting procedure described below. This allows for gradual temperature increase of the appliance and of the conduits and for easier start of the draft. This method is also more environmentally friendly than a traditional lighting because it reduces pollution caused by combustion gases (in traditional fire starting, these gases are released by big logs in a cold hearth that does not allow to burn them).

The air register should be left as much open as possible (< + > position) during the lighting and the first reloading.

### RELOADING

It is recommended to wait until there are only embers left (no flames and smoke) before adding other logs. The door must be opened gradually in order to limit the inflow of air that would increase smoke release in the room. The damper must be opened (register moved to the right < + >) before opening the door to reload.

The appliance had intermittent operation and the reloading interval at the rated thermal output is about 45 minutes. Reloading maximum height: 250mm or 5kg (about 4-5 small diameter logs 25cm long).

Use of glove for recharging operations is compulsory. Risk of serious burn injuries.

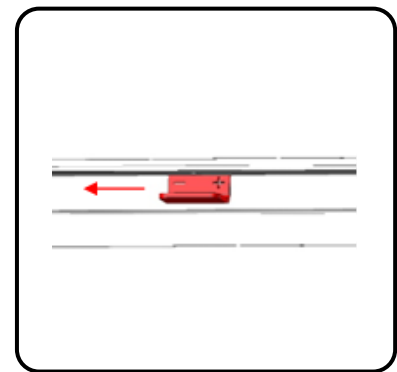
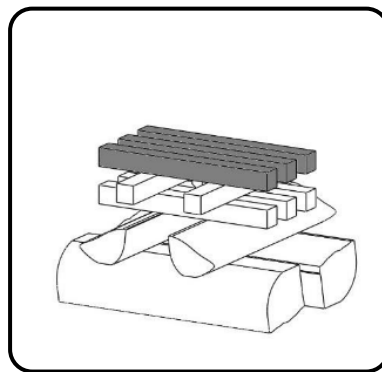
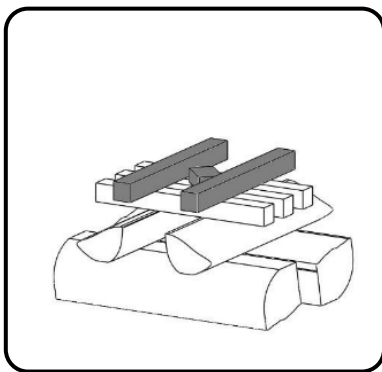
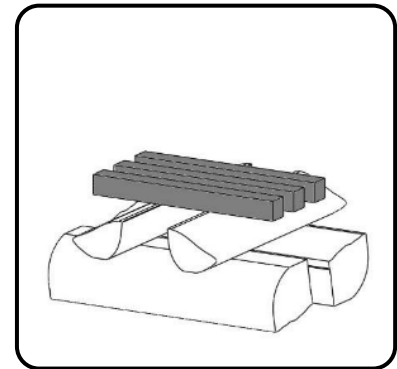
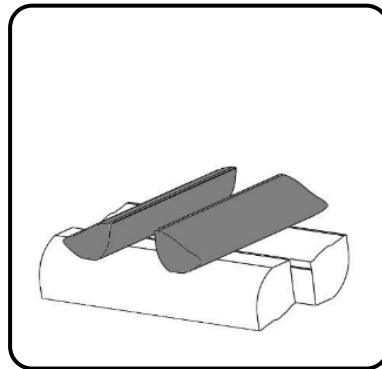
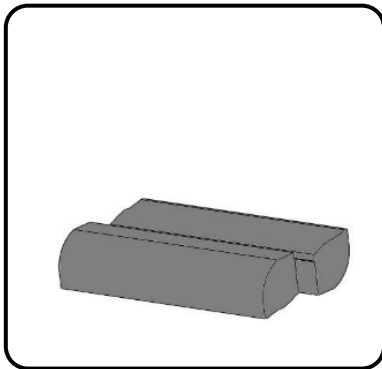

### FUELS

It is recommended to burn only hard wood. Use split log sizes suitable to the hearths and that seasoned for at least two years. Logs must be kept in a sheltered place. If the wood is too damp, it can dirty the glass, the hearth, internal walls and the flue.

**Do not use this appliance as an incinerator.**

**Do not use liquid fuels or any fuels that are not approved for this appliance.**

**Damage caused by the use of non-recommended fuels is not covered.**

### FIRST FIRE

Before operation, ensure the surrounding construction is complete and fully dry if installed with the firebox. Depending on relative humidity, this may require 3 to 5 weeks.

The appliance is finished with a high-temperature paint that cures during the initial firings. Do not touch the appliance during these first heat cycles, as the paint is still hardening and may be damaged. The first fire should be small and moderate, using minimal wood. Gradually increase the intensity with subsequent fires.

During initial use, the appliance may emit smoke and a paint odour. This is normal. Ensure the room is well ventilated until it clears.

**OPERATION & MAINTENANCE**

**SAFETY WARNING:** Do not touch, clean, or service the appliance while it is hot, as this may cause serious burns. All maintenance must be carried out when the appliance is completely cold.

**FLUE:** In order to ensure correct operation of the appliance, it is necessary to periodically clean the appliance, flue connection, and the flue. When the appliance has not been used for a long time, it is essential to make sure that there are no obstructions in the flue before starting a fire. The convection grids must also be checked and kept clean. Regular maintenance of the appliance by a qualified technician is needed. It is recommended to perform these maintenance operations during cleaning of the flue.

**DOOR SEALS:** Door seals are wear components must be replaced over time to maintain an airtight seal. Replacement seals are available through your local Sculpt Fireplace retailer.

**ASH REMOVAL:** In order to ensure correct operation of the appliance, the ash drawer must be emptied regularly to prevent leakage and to avoid clogging the ash grid.

Remove the ash only when embers are completely cold (they can remain hot for up to 24 hours after the fire has been extinguished).

The ash drawer is located under the ash grate. To properly handle this plate, it is better to clean the firebox using an ash vacuum cleaner or a brush and dustpan.

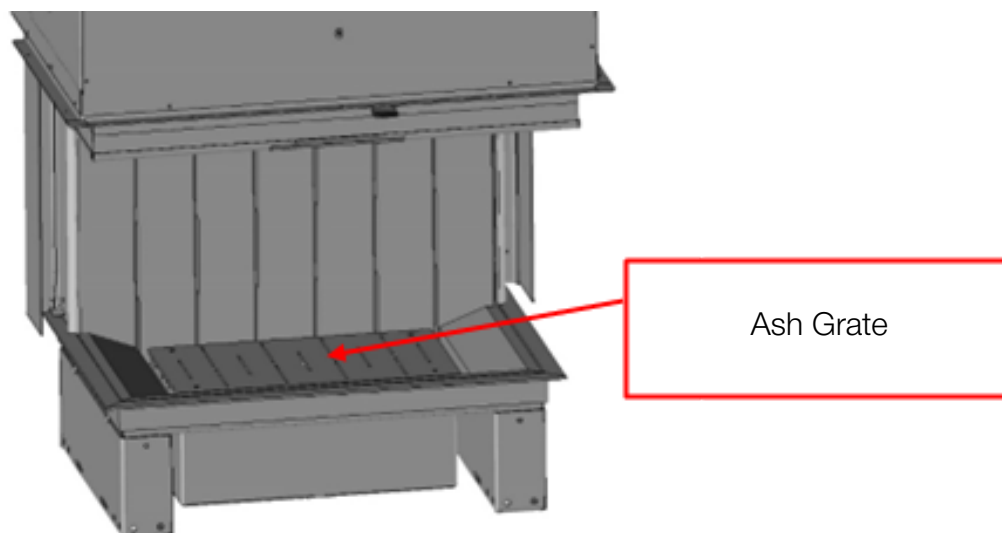

**GLASS CLEANING**

The FAS120 range is equipped with a glass cleaning system that assists in reducing creosote deposit on the glass.

The effectiveness of this cleaning system depends on several factors such as draft, wood moisture and combustion intensity. The use of wood with moisture exceeding 20% causes an excessive darkening of the glass. We suggest once again to only burn very dry wood.

The glass must only be cleaned when it is cold. Use of a damp piece of newspaper dipped in cold ash is an efficient and environmentally friendly way to clean the glass before rinsing it with clean water.

It is also possible to use specific products intended for this use. The product must be applied on a soft cloth and not directly on the glass. Some aggressive products can cause deterioration of the paint, of the backline decorations on the glass, of the door seals and of the glass itself.

**3-Sided Fireboxes**

Your firebox is equipped with a front fixed panel and two side mobile glass panels. The side glass openings allow you to clean the glass panels and to access the front glass in order to clean it.

These operations must be performed with the lift door in low position.

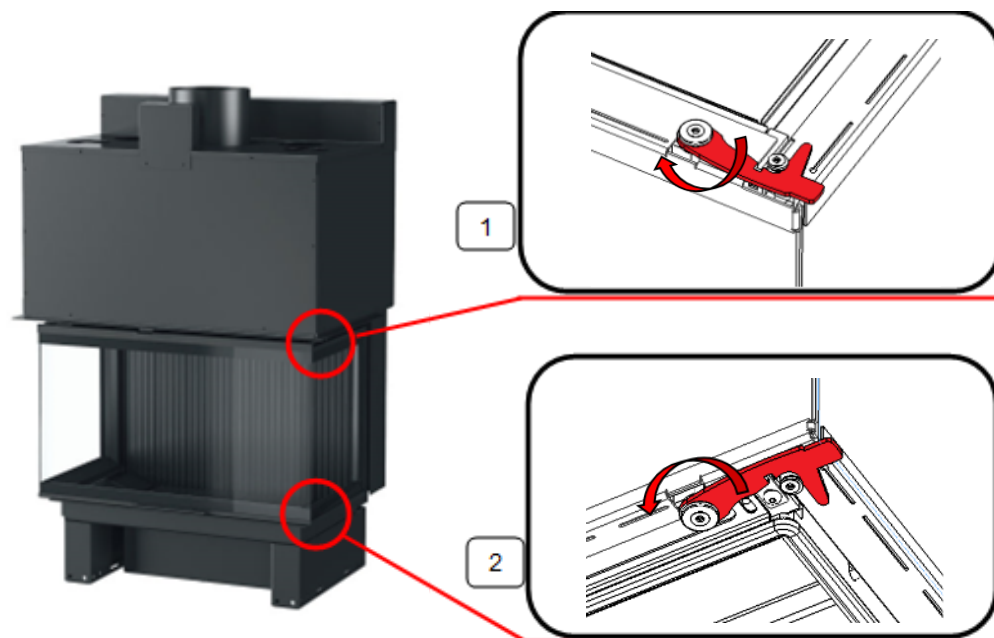
**3V FIREBOXES**

*\*This operation is to be carried out by a qualified professional.*

**VLD/G FIREBOXES**

VLD/G fireboxes are fitted with a front glass panel and one fixed side glass panel. The front glass opening system provides access for cleaning both the front and side glass surfaces. All cleaning and maintenance must be carried out with the lift door in the fully lowered position.

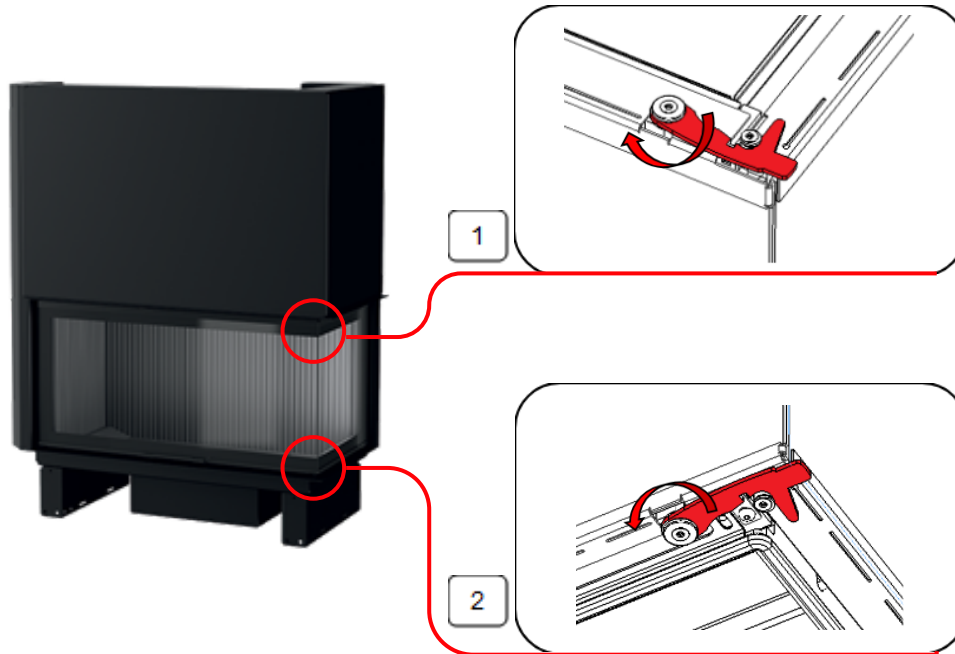

**Single-sided & Double-sided Fireboxes**

Your firebox is fitted with one or two movable glass panels. These panels are designed to provide access for cleaning the glass surfaces. All cleaning and maintenance must be carried out with the lift door in the fully lowered position.

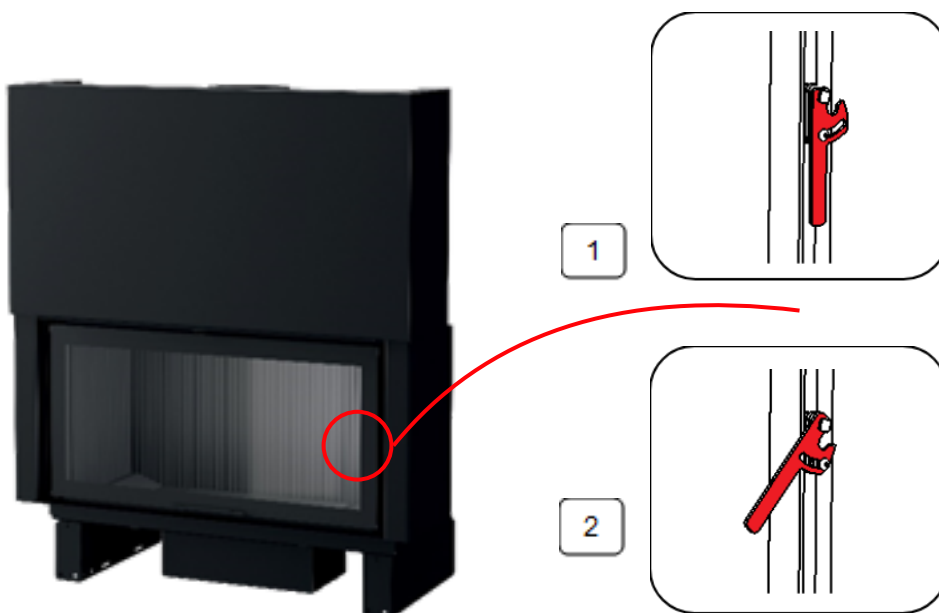

*\*This operation is to be carried out by a qualified professional.*

## 4.4 Warranty

### **WARRANTY**

AXIS appliances are designed and manufactured to provide long-term performance and reliability. In the unlikely event of a manufacturing fault, Sculpt Fireplaces Pty Ltd will work with the supplying dealer to provide an appropriate solution in accordance with the warranty terms outlined below.

Incorrect installation is not covered under warranty. If any intervention by Sculpt Fireplaces Pty Ltd is required, including site visits, phone support or video assistance, and the issue is determined to be caused by incorrect installation, all associated administration, travel and call-out costs will be payable by the customer.

Refer to the warranty table for applicable warranty periods.

This warranty is limited to the replacement of parts confirmed to be defective due to manufacturing fault. The warranty does not cover installation, removal, reinstallation, freight, packaging, travel, labour or any associated consequential costs.

Any parts replaced under warranty are covered only for the remaining balance of the original warranty period.

The following items are considered consumable components and are not covered under warranty:

- Glass
- Door seals and gaskets
- Thermal screens
- Components exposed directly to flames, embers or excessive heat
- Surface finishes and paint deterioration caused by use

Damage, deterioration or operational issues caused by incorrect installation, misuse, lack of maintenance, over firing, water exposure, environmental conditions or non-compliant operation are not covered under warranty.

Sculpt Fireplaces Pty Ltd and AXIS will not be held responsible where any of the following conditions have not been met:

- The appliance has not been installed in accordance with AS/NZS 2918:2018 and all applicable local regulations
- The appliance has not been installed in accordance with these installation instructions
- The appliance has been modified or altered in any way
- The appliance has not been operated or maintained as outlined within this manual
- Non-genuine or non-approved replacement parts have been used

Only genuine AXIS replacement parts supplied or approved by Sculpt Fireplaces Pty Ltd may be used on the appliance.

## 4.4 Warranty

AXIS WARRANTY TABLE

PRODUCT	ITEM	DURATION
<b>FAS120 SS</b> <b>FAS120 DS</b> <b>FAS120 VLD</b> <b>FAS120 VLG</b> <b>FAS120 3V</b>	Firebox Firebox Mechanism	10 Years 5 Years
	Ash Grates Glass Seals Baffle Supports Baffle Plates Ash Pan	N/A

## 4.5 Disclaimer

---

### **DISCLAIMER**

Whilst every effort is taken to avoid errors, Sculpt Fireplace Collection cannot accept responsibility for the accuracy of any statement, extract or information contained within this manual nor can any of its contributors who have submitted material for inclusion. Sculpt Fireplace Collection may change or update this manual and anything described in it without notice. We will endeavour to ensure that information, materials and data on this site are complete, accurate and up-to-date. Information on this manual is for guidance only and cannot cover all circumstances. E&OE

*©Copyright 2026 Sculpt Fireplace Collection*

SCULPT™  
FIREPLACE  
COLLECTION

©Copyright 2026 Sculpt Fireplace Collection

05.2026 V1